

# **FV5 Series Rotary EtherCAT Bus Servo Drive**

## **Installation Guide**

**Document Version: 01**

**Publication Date: 2025-02-25**



Any textual descriptions, text formatting, illustrations, photographs, methods, and other content in this document, unless otherwise specified, are the property of Shanghai Flexem Technology Co., Ltd. (herein after referred to as “Flexem”) and are protected by intellectual property and copyright laws. No individual or organization may reproduce or quote any part of this document in any way without the written authorization and permission of Flexem.

Any organization or individual authorized to use the content in this document should use it within the authorized scope and indicate the source as “Source: Flexem”. Flexem reserves the right to pursue legal action against anyone who violates the above statement.

Except for the trademarks of Shanghai Flexem Technology Co., Ltd., other trademarks, product logos, and product names appearing in this manual are owned by their respective rights holders.

## Revision History

Date	Version	Revision History
2025-02-25	01	Initial publication

## Contents

<b>Preface .....</b>	<b>I</b>
<b>Safety Precautions .....</b>	<b>1</b>
Safety Disclaimer.....	1
Safety Symbols .....	1
Safety Precautions .....	1
Safety Guidelines .....	1
Storage and Transportation Handling Precautions.....	1
Unpacking Precautions .....	2
Installation Precautions.....	2
Handling Precautions .....	2
Maintenance Precautions .....	3
Repair Precautions .....	3
<b>1 Product Information.....</b>	<b>4</b>
1.1 Servo Drive.....	4
1.1.1 Servo Drive Model Description .....	4
1.1.2 Drive Nameplate Description.....	5
1.1.3 Product Appearance .....	5
1.1.4 Product Specifications .....	8
1.2 Servo Motors .....	17
1.2.1 Servo Motor Model Description .....	17
1.2.2 EAM-W Series Servo Motors .....	17
1.3 Servo Drive and Servo Motor Matching Description .....	21
<b>2 Installation Operation .....</b>	<b>24</b>
2.1 Installs the Servo Drive .....	24
2.1.1 Installation Location .....	24
2.1.2 Installation Environment Conditions .....	24
2.1.3 Installation Method and Precautions.....	24
2.2 Servo Motor Installation .....	26
2.2.1 Installation Location .....	26
2.2.2 Environmental Conditions .....	26
2.2.3 Installation Precautions .....	27
<b>3 Peripheral Devices and Wiring.....</b>	<b>29</b>

3.1 Peripheral Device Wiring Diagram.....	29
3.1.1 SIZE-A/SIZE-B Type .....	29
3.1.2 SIZE-C/SIZE-D/SIZE-E Type .....	30
3.1.3 System Wiring and Key Points Description.....	31
3.1.4 Wiring Key Points.....	32
3.2 Cable and Peripheral Accessories Selection .....	34
3.2.1 List of Matching Cables for Drives and Motors .....	34
3.2.2 Servo Accessories .....	37
3.2.3 Communication Cable Accessories.....	38
3.2.4 Control Cable Accessories .....	38
3.2.5 Options for Peripheral Electrical Components .....	38
3.3 CN1 Connector Wiring.....	45
3.3.1 Definition of CN1 Connector Terminals.....	46
3.3.2 Connection to the Upper Controller.....	49
3.3.3 Connection of Control Input Signal.....	50
3.3.4 Connection of Analog Command Input Signal(applicable to the U3 series) .....	51
3.3.5 Connection of Control Output Signal .....	52
3.3.6 Connection of Frequency Division Pulse Output Signal .....	53
3.3.7 Connection of Brake Signal .....	54
3.4 Wiring of Connector CN2.....	55
3.5 Wiring of Connector CN3.....	56
3.5.1 Wiring of the Communication Encoder .....	56
3.5.2 Key Points for Wiring of Communication Encoders .....	57
3.6 Wiring of Connector CN4.....	57
3.6.1 Wiring of Incremental Encoder.....	58
3.7 Wiring of Main circuit .....	58
3.7.1 Main Circuit Terminal Connection Cable Recommendations .....	59
3.7.2 Definition of SIZE-A/SIZE-B Connector CN5 Interface .....	60
3.7.3 Definition of SIZE-C/SIZE-D Connector CN5/CN6/CN7 Interface .....	61
3.7.4 Definition of SIZE-E Connector CN5 Interface .....	62
3.7.5 Brake Resistor Selection and Wiring Precautions.....	62
3.8 Wiring of EtherCAT Communication Port .....	62
3.9 Wiring of Connector CN9 (Applicable to the U3 Series).....	63

3.9.1 Wiring method When Using External 24V Power Supply.....	63
3.9.2 Wiring method When using Internal 24V Power Supply.....	64
3.10 Motor Side Connector Wiring.....	64
3.11 Electromagnetic Interference Suppression.....	68
3.11.1 Anti- electromagnetic interference Wiring Example.....	68
3.11.2 Grounding .....	69
3.11.3 How to Use Input Power Filter and Noise Filter.....	69
3.11.4 Magnetic Rings .....	70
3.11.5 Other Suggestions on Electromagnetic Interference Suppression .....	71
<b>4 Appendix.....</b>	<b>72</b>
4.1 Compliance with Certifications and Standards.....	72
4.1.1 CE Certification .....	72

# Preface

## Overview

Thank you for choosing Flexem products. The FV5 series rotary EtherCAT bus servo drive is an essential component of servo systems. By receiving and responding to commands from the upper controller, it accurately controls the position, velocity, and output torque of the rotary motor, meeting the application needs of customers in various production scenarios. The FV5 series rotary EtherCAT bus servo drive is rich in features, excellent in performance, has a high control bandwidth, and supports various command form such as EtherCAT communication and analog input (applicable to U3 series). It supports user-friendly functions such as automatic adjustment, adaptive vibration suppression, inertia identification, low-frequency jitter suppression, error compensation, etc. It can also be optimized through servo commissioning software, making it widely applicable in fields such as consumer electronics, semiconductors, lithium batteries, photovoltaics, and more.

This manual provides detailed instructions to the hardware specifications and installation methods of the FV5 series rotary EtherCAT bus servo drive.

The content provided in this manual serves as general guidance and does not guarantee coverage of all usage scenarios for all product models. Due to reasons such as version upgrades, different equipment models, and different configuration files, the information provided in the manual may not correspond exactly to the actual device interface used by the user. Therefore, users should refer to the actual information on the device interface for accuracy. The manual does not further explain the differences caused by the aforementioned situations.

For functionality introduction and configuration examples, this manual may use IP addresses, URLs, domain names, etc. If not specifically stated, the aforementioned content is provided as examples and does not represent any actual significance.

## Intended Audience

This document is primarily intended for readers who wish to understand the installation method of the FV5 series rotary EtherCAT bus servo drive, including electrical engineers, mechanical engineers, etc. It is assumed that readers have a certain level of knowledge in the following areas:

- ◆ Principles of automatic control
- ◆ Basic electrical knowledge
- ◆ Principles of servo system's functionalities
- ◆ Applications of sensors

## Getting Help

If you encounter any problems during use, please call our service hotline at 4008-033-022.

For more documents, please visit [https://www.flexem.com/info\\_download.html](https://www.flexem.com/info_download.html).

### Contact Information

Address: 9th Floor, Building A, INNO Business Park, No. 386 Guo'an Road, Yangpu District, Shanghai

Zip Code: 200043





Website: <https://www.flexem.com>

# Safety Precautions

## Safety Disclaimer

To ensure personal and equipment safety, please read and follow these safety precautions before installing, operating, or maintaining the product. Non-professionals are strictly prohibited from performing equipment installation, wiring, maintenance, inspection, or component replacement! This product should be used in an environment that meets the design specifications; otherwise, it may cause failure. Functional abnormalities or component damage resulting from failure to comply with relevant regulations are not covered by the product quality guarantee. Flexem will not be liable for personal safety accidents or property losses caused by improper operation.

## Safety Symbols

Symbol	Meaning	Description
	Warning	The content following this icon requires special attention; failure to do so may result in personal injury or equipment damage.
	Hazardous Voltage	Indicates a potential hazard of excessive voltage.
	Protective Earthing	Indicates a terminal that provides protection against electric shock when the connected conductor fails, or a protective grounding electrode terminal.
	Warning, Hot Surface	Indicates that the marked object has a high temperature and should be touched with caution.

## Safety Precautions

### Safety Guidelines

The servo drive must be used in accordance with all applicable safety regulations, directives, and all technical specifications!



The servo drive operates at a hazardous voltage level and must be properly grounded.



Only qualified personnel with adequate technical training and knowledge can perform installation, operation, inspection, and maintenance procedures.

### Storage and Transportation Handling Precautions



- ◆ Avoid storing or transporting the equipment in environments with water splash, rain, direct sunlight, strong electric field, strong magnetic field, and strong vibration.
- ◆ Avoid storing the equipment for more than three months. Long-term storage requires stricter protection and necessary inspections.
- ◆ Never transport the equipment with other equipment or materials that may harm or have negative impacts on this equipment.
- ◆ Handle the equipment with care during transportation and mind your steps to prevent personal injuries or equipment damage.

- ◆ Pack the equipment strictly before transportation. Use a sealed box for long-distance transportation.
- ◆ Large-scale or heavy equipment must be transported by qualified professionals using specialized hoisting equipment. Failure to comply may result in personal injuries or equipment damage.
- ◆ Before hoisting the equipment, ensure the equipment components such as the front cover and terminal blocks are secured firmly with screws. Loosely-connected components may fall off and result in personal injuries or equipment damage.
- ◆ Never stand or stay below the equipment when the equipment is being hoisted by the hoisting equipment.
- ◆ When hoisting the equipment with a steel rope, ensure the equipment is hoisted at a constant speed without suffering from vibration or shock. Do not turn the equipment over or let the equipment stay hanging in the air. Failure to comply may result in personal injuries or equipment damage.

## Unpacking Precautions



- ◆ Never install the equipment if you find damage, rust, or signs of use on the equipment or accessories upon unpacking.
- ◆ Never install the equipment if you find water seepage or missing or damaged components upon unpacking.
- ◆ Never install the equipment if you find the packing list does not conform to the equipment you received.
- ◆ Unpack the package by following the unpacking sequence. Do not strike the package violently.

## Installation Precautions

Please install in strict accordance with the precautions to avoid personal and property damage.



- ◆ It is strictly prohibited to power the servo drive using an IT network. Use only TN/TT grid power.
- ◆ The servo drive must be grounded through the AC mains ground wire.
- ◆ The ground wire of the upper unit connected to the servo drive must be the same as the servo drive's ground wire.
- ◆ The equipment must be operated only by professionals with electrical knowledge.
- ◆ Read through the guide and safety instructions before installation.
- ◆ Wiring with the power on is prohibited. Wait at least 15 minutes after disconnecting the power before making contact.
- ◆ Wear an anti-static wrist strap during wiring and other operations to prevent damage to internal electronic components.
- ◆ The cables used for wiring must meet the required wire diameter and shielding specifications. The shielding layer of shielded cables must be reliably grounded at one end.

## Handling Precautions



- ◆ Before powering up, ensure that the supply voltage matches the rated voltage and that the wiring is secure to prevent injury to personnel or damage to the equipment.
- ◆ Before powering up, verify that the wiring sequence is correct. Pay special attention to avoid misconnecting the input cable to the output, as this could damage the device.
- ◆ When the unit is powered up, the mechanism may activate suddenly. Stay clear of the mechanism to avoid injury.

- ◆ Never touch the terminals or disassemble any parts while the equipment is energized to prevent electric shock.
- ◆ Never touch the equipment casing, discharge resistors, or other components to avoid burns from high temperatures.
- ◆ Avoid dropping objects or metal into the unit, as this may cause damage.
- ◆ The machine owner and operator must ensure the machine is energized and prevent unauthorized personnel from entering the hazardous area.

## Maintenance Precautions



- ◆ Equipment installation, wiring, maintenance, inspection, or parts replacement must be performed only by professionals.
- ◆ It is strictly prohibited to conduct equipment maintenance while the equipment is powered on. Otherwise, there is a risk of electric shock.
- ◆ Before maintenance, cut off all the power supplies of the equipment and wait for at least the time designated on the equipment warning label.
- ◆ In case of a permanent magnet motor, do not touch the motor terminals immediately after power-off because the motor terminals will generate induced voltage during rotation even after the equipment power supply is off. Failure to comply will result in an electric shock.
- ◆ Perform routine and periodic inspection and maintenance on the equipment according to maintenance requirements and keep a maintenance record.

## Repair Precautions



- ◆ Equipment installation, wiring, maintenance, inspection, or parts replacement must be performed only by professionals.
- ◆ It is strictly prohibited to conduct equipment maintenance while the equipment is powered on. Otherwise, there is a risk of electric shock.
- ◆ Before inspection and repair, cut off all the power supplies of the equipment and wait for at least the time designated on the equipment warning label.
- ◆ When the equipment is faulty or damaged, the troubleshooting and repair work must be performed by professionals that follow the repair instructions, with repair records kept properly.
- ◆ Never use damaged equipment. Failure to comply may result in death, personal injuries, or severe equipment damage.
- ◆ After the equipment is replaced, check the wiring and set parameters again.
- ◆ Recycle retired equipment by observing industry waste disposal standards to avoid environmental pollution.

# 1 Product Information

## 1.1 Servo Drive

### 1.1.1 Servo Drive Model Description

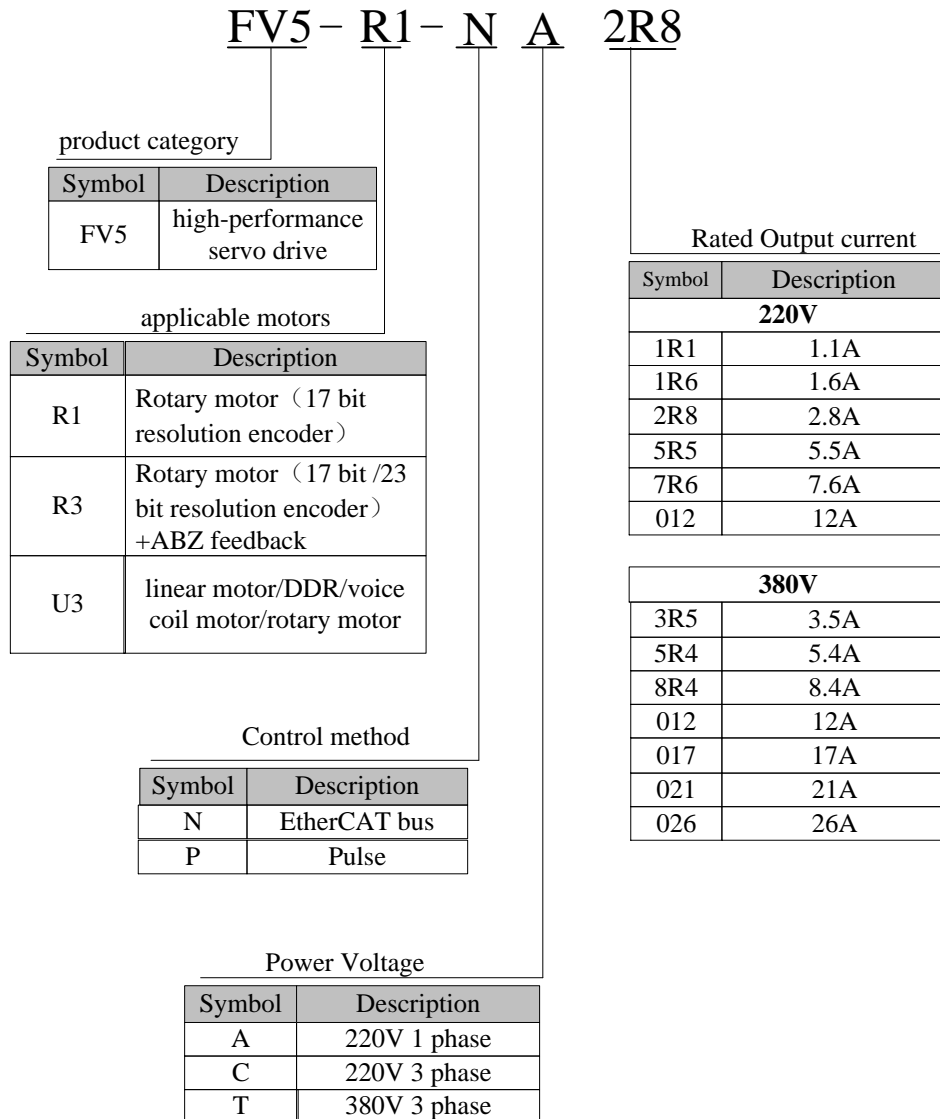

Note: If the drive model suffix is A00 or empty, the drive is a standard model.

- ◆ R1 series support 17-bit resolution absolute encoder (Tamagawa) ;
- ◆ R3 series support 17-bit resolution absolute encoder (Tamagawa), 23-bit resolution absolute encoder (Tamagawa), and ABZ encoder;
- ◆ U3 series support 17-bit resolution absolute encoder (Tamagawa), 23-bit resolution absolute encoder (Tamagawa), BISS-C encoder, EnDat encoder, and ABZ encoder.

### 1.1.2 Drive Nameplate Description

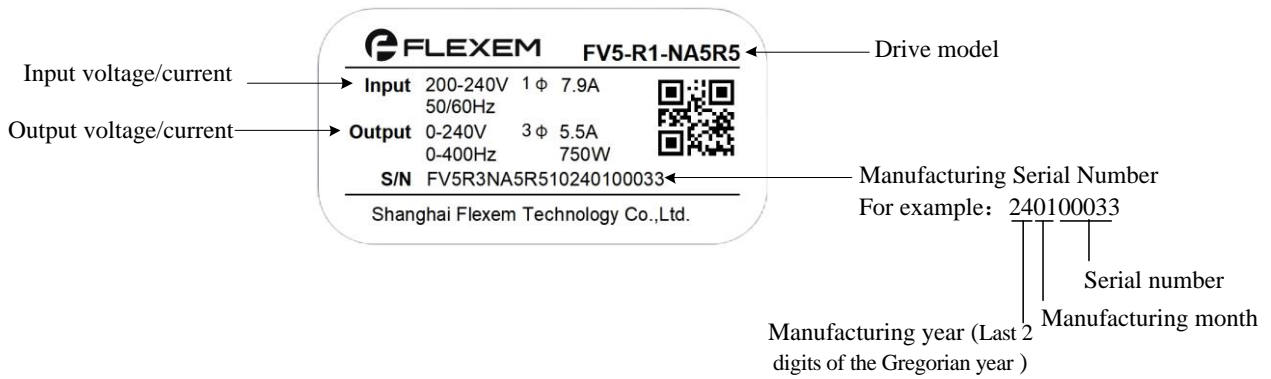

### 1.1.3 Product Appearance

#### 1.1.3.1 SIZE-A/SIZE-B Type

◆ R1 and R3 series

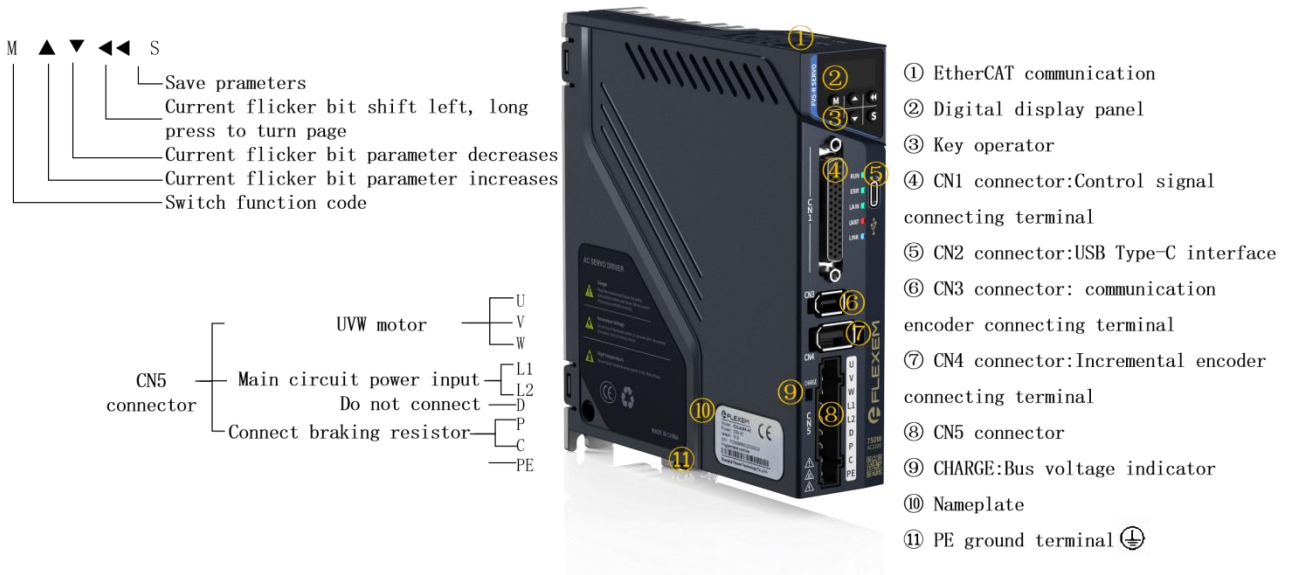

◆ U3 series

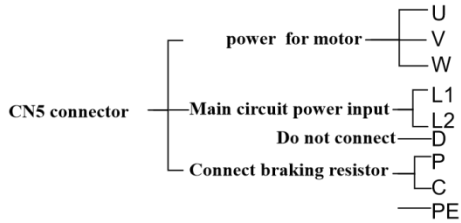
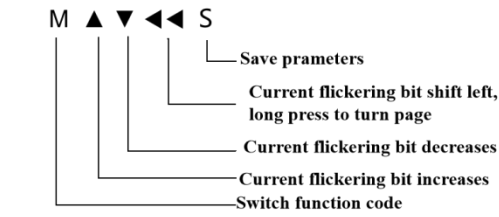

- ① EtherCAT communication
- ② STO terminal
- ③ Digital display panel
- ④ Key operator
- ⑤ CN1 connector: Control signal connecting terminal
- ⑥ CN2 connector: USB Type C port
- ⑦ CN3 connector: connect to communication encoder
- ⑧ CN4 connector: connect to incremental encoder
- ⑨ CN5 connector
- ⑩ CHARGE: Bus voltage indicator
- ⑪ PE ground terminal

### 1.1.3.2 SIZE-C/SIZE-D Type

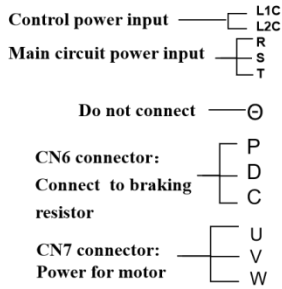
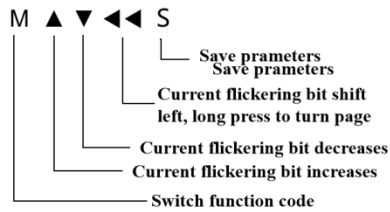

- ① EtherCAT communication port
- ② Digital display panel
- ③ Key operator
- ④ CN2 connector: USB Type-C port
- ⑤ CN1 connector: Control signal connecting terminal
- ⑥ CN3 connector: Connect to communication encoder
- ⑦ CN4 connector: Connect to incremental encoder
- ⑧ CN5 connector
- ⑨ CN6 connector
- ⑩ CN7 connector
- ⑪ PE ground terminal
- ⑫ CHARGE: bus voltage indicator
- ⑬ Nameplate

Note: Only the U3 series support STO terminals, please refer to the SIZE-A/SIZE-B of U3 series .

### 1.1.3.3 SIZE-E Type

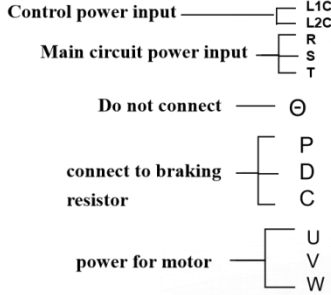
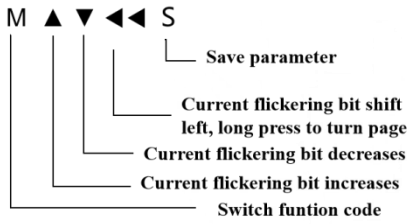

- ① EtherCAT communication port
- ② Digital display panel
- ③ Key operator
- ④ CN2 connector: USB Type-C port
- ⑤ CN1 connector: Control signal connecting terminal
- ⑥ CN3 connector: Connect to communication encoder
- ⑦ CN4 connector: Connect to incremental encoder
- ⑧ CN5 connector
- ⑨ CN5 connector
- ⑩ CN5 connector
- ⑪ PE ground terminal
- ⑫ CHARGE: Bus voltage indicator
- ⑬ Nameplate

Note: Only the U3 series support STO terminals, please refer to the SIZE-A/SIZE-B of U3 series.

### 1.1.3.4 Indicator Status Instruction

Indicator	Status	Meaning
RUN	Off	Init state
	Flashes ( on for 200ms/ off for 200ms )	Pre-Operational state
	Single flash ( on for 200ms/off for 1000ms )	Safe-Operational state
	On	Operational state
ERR	Off	Network is good
	Flashes ( on for 200ms/off for 200ms )	Abnormal communication setting
	Single flash ( on for 200ms/off for 1000ms )	Synchronization event exception
	Double-flash ( on for 200ms, off for 200ms, on for 200ms, off for 1000ms )	App watchdog timeout
L/A IN	Off	Link is not established
	Quick flash ( on for 50ms/off for 50ms )	Link is established, data sent and received
	On	Link is established, no data sent and received
L/A OUT	Off	Link is not established
	Quick flash ( on for 50ms/off for 50ms )	Link is established, data sent and received
	off	Link is established, no data sent and received

Indicator	Status	Meaning
LINK	On	Bluetooth is connected
	Flash	Bluetooth is not connected

## 1.1.4 Product Specifications

### 1.1.4.1 Electrical Specifications

Model	FV5-R*- NA1R1- ***	FV5-R*- NA1R6- ***	FV5-R*- NA2R8- ***	FV5-R*- NA5R5- ***	FV5-R*- NC7R6- ***	FV5-R*- NC012- ***
Input Power	Single-Phase/Three-Phase AC 200V~240V, -15%~+10%, 50/60Hz					
Rated Output Current (ARMS)	1.1	1.6	2.8	5.5	7.6	12
Peak Output Current (ARMS)	3.9	5.9	10.1	16.9	23	32
Output Power (W)	100	200	400	750	1000	1500
Heat Dissipation Method	Natural Cooling			Fan Cooling		
Dynamic Brake	Built-in					
Brake Resistor	Externally Connected Brake Resistor			Built-in Brake Resistor Can be connected externally		
Minimum Resistance of External Brake Resistor ( $\Omega$ )	40	40	40	40	20	15
Installation Dimensions	SIZE-A			SIZE-B	SIZE-C	SIZE-D

Note: FV5-R1-NA5R5 has no built-in brake resistor.

Model	FV5-R*- NT3R5-***	FV5-R*- NT5R4-***	FV5-R*- NT8R4-***	FV5-R*- NT012-***	FV5-R*- NT017-***	FV5-R*- NT021-***	FV5-R*- NT026- ***
Input Power	Three-Phase AC 380V~440V, +10~15%, 50/60Hz						
Rated Output	3.5	5.4	8.4	12	17	21	26

Model	FV5-R*- NT3R5-***	FV5-R*- NT5R4-***	FV5-R*- NT8R4-***	FV5-R*- NT012-***	FV5-R*- NT017-***	FV5-R*- NT021-***	FV5-R*- NT026- ***
Current (ARMS)							
Peak Output Current (ARMS)	11	14	20	30	42.5	52.5	65
Output Power (W)	1000	1500	2000	3000	5000	6000	7500
Heat Dissipation Method	Fan Cooling						
Dynamic brake	Built-in						
Brake Resistor	Built-in brake resistor, can be connected externally						
Minimum Resistance of External Brake Resistor ( $\Omega$ )	80	60	45	40	35	25	25
Installation Dimensions	SIZE-C		SIZE-D		SIZE-E		

Model	FV5-U3- NA1R1	FV5-U3- NA1R6	FV5-U3- NA2R8	FV5-U3- NA3R0	FV5-U3- NA4R5	FV5-U3- NA5R5	FV5-U3- NA6R0
Input power	Single-phase AC 200V~240V, -15%~+10%, 50/60Hz						
Rated Output Current(A RMS)	1.1	1.6	2.8	3.0	4.5	5.5	6.0
Peak Output Current(A)	3.9	5.9	10.1	10	13.5	16.9	18.0

Model	FV5-U3-NA1R1	FV5-U3-NA1R6	FV5-U3-NA2R8	FV5-U3-NA3R0	FV5-U3-NA4R5	FV5-U3-NA5R5	FV5-U3-NA6R0
RMS)							
Output Power(W)	100	200	400	400	600	750	1000
Heat Dissipation Method	Natural Cooling					Fan Cooling	
Dynamic Brake	Built-in						
Built-in Brake Resistor	Externally Connected Brake Resistor					50 Ω /50W	
Minimum Resistance of External Brake Resistor (Ω)	40						
Installation Dimensions	SIZE-A					SIZE-B	

Model	FV5-U3-NC7R6	FV5-U3-NC8R0	FV5-U3-NC010	FV5-U3-NC012
Input Power	Three-Phase AC 200V~240V, -15%~+10%, 50/60Hz			
Rated Output Current (ARMS)	7.6	8.0	10.0	12.0
Peak Output Current (ARMS)	23	23	23	32
Output Power (W)	1000	1200	1400	1500
Heat Dissipation Method	Fan Cooling			
Dynamic Brake	Built-in			
Built-in Brake Resistor	25 Ω /80W			
Minimum Resistance of External Brake	20	20	15	15

Model	FV5-U3-NC7R6	FV5-U3-NC8R0	FV5-U3-NC010	FV5-U3-NC012
Resistor ( $\Omega$ )				
Installation Dimensions	SIZE-C		SIZE-D	

Model	FV5-U3-NT3R5	FV5-U3-NT5R4	FV5-U3-NT6R0	FV5-U3-NT8R0	FV5-U3-NT8R4
Input Power	Three-phase AC 380V~440V, +10%~15%, 50/60Hz				
Rated Output Current (ARMS)	3.5	5.4	6.0	8.0	8.4
Peak Output Current (ARMS)	11	14	15	20	20
Output Power (W)	1000	1500	1500	2000	2000
Heat Dissipation Method	Fan Cooling				
Dynamic Brake	Built-in				
Built-in Brake Resistor	100 $\Omega$ /80W	100 $\Omega$ /80W	100 $\Omega$ /80W	50 $\Omega$ /80W	50 $\Omega$ /80W
Minimum Resistance of External Brake Resistor ( $\Omega$ )	80	60	60	45	45
Installation Dimensions	SIZE-C			SIZE-D	

### 1.1.4.2 Basic Specifications

Item	Description	
Basic Specifications	Control Method	
	IGBT PWM control, sine wave current drive method	
	Encoder Feedback	Linear servo motor
Rotary servo motor		◆ R1 series support 17-bit resolution absolute encoder (Tamagawa) ;

Item			Description
	Control Signal	DI Input	<ul style="list-style-type: none"> <li>◆ R3 series support 17-bit resolution absolute encoder (Tamagawa), 23-bit resolution absolute encoder (Tamagawa), and ABZ encoder;</li> <li>◆ U3 series support 17-bit resolution absolute encoder (Tamagawa), 23-bit resolution absolute encoder (Tamagawa), BISS-C encoder, EnDat encoder, and ABZ encoder</li> </ul>
		DO Output	<ul style="list-style-type: none"> <li>◆ 5 general inputs(applicable to the R1 and R3 series)</li> <li>◆ 3 general inputs and 2 high-speed input(applicable to the U3 series)</li> </ul> General input functions selected via parameters
	Analog Signal	Input	<ul style="list-style-type: none"> <li>◆ 4 general outputs (applicable to the R1 and R3 series)</li> <li>◆ 2 general outputs and 2 high-speed outputs (applicable to the U3 series)</li> </ul> General output functions selected via parameters
	Communication Function	USB	1* 16Bit A/D input (applicable to the U3 series)
	Dynamic Brake		USB Type-C Port, connect to PC, etc.
	Control Modes		Built-in
			Velocity mode, torque mode, position mode, velocity/torque/position hybrid mode Above 4 control modes can be switched via parameters
Performance	Velocity Variation Rate*1	Load Variation Rate	load rate from 0 to 100%(at the rated velocity ):Within $\pm 0.1\%$
		Voltage Variation Rate	voltage fluctuation: $\pm 10\%$ of the rated voltage(at the rated velocity), 0.1%
		Temperature Variation Rate	$25 \pm 25^{\circ}\text{C}$ (at the rated velocity):Within $\pm 0.1\%$
	Velocity Control Range		1~6000 RPM
	Velocity Control Bandwidth		3.5kHz
	Torque Control Accuracy		$\pm 1\%$
		Circuit Time Parameter	Approximately 47 $\mu\text{s}$
Encoder Frequency Division Pulse Output	Output Form		Phase A, Phase B: Differential output Phase Z: Differential output or open collector output
	Frequency Division Ratio		Arbitrary frequency division ratio
Input/Output	Digital Input	Changeable	5* DI

Item			Description
Signal	Signal	Signal Allocation	DI Functions: Servo enablement, alarm reset, gain switch, positive overtravel switch, negative overtravel switch, origin switch
	Digital Output Signal	Changeable Signal Allocation	4* DO DO Functions: Servo ready, motor rotation, zero speed signal, speed consistency, positioning completion, brake output, warning output, fault output, torque reached.
Built-in Functions	Overtravel (OT) Prevention Function		Stops immediately when P-OT or N-OT actions occur
	Protection Functions		Overcurrent, overvoltage, undervoltage, overload, main circuit detection abnormality, radiator overheat, power phase loss, overspeed, encoder abnormality, CPU abnormality, parameter abnormality, others
	LED Display Functions		Main power CHARGE, 5-digit LED display
	Vibration Suppression		Supports low frequency suppression 0~100Hz Supports mid-to-high frequency suppression 100~5000Hz
	Others		Gain adjustment, alarm record, JOG operation

Note \*1: The velocity variation rate is defined by the following formula:

$$\text{Velocity Variaton Rate} = \frac{\text{No Load Velocity} - \text{Full Load Speed}}{\text{Rated Velocity}} * 100\%$$

In practice, voltage changes and temperature changes will cause amplifier deviation, resulting in changes in the hydrochloric acid resistance value. This effect is reflected in velocity changes. The velocity changes are expressed as the velocity change rate due to voltage changes and temperature changes based on the rated velocity.

### 1.1.4.3 Servo Drive Installation Dimensions

◆ The installation dimensions of Size -A (in mm) are shown below. It weighs 0.8 kg.

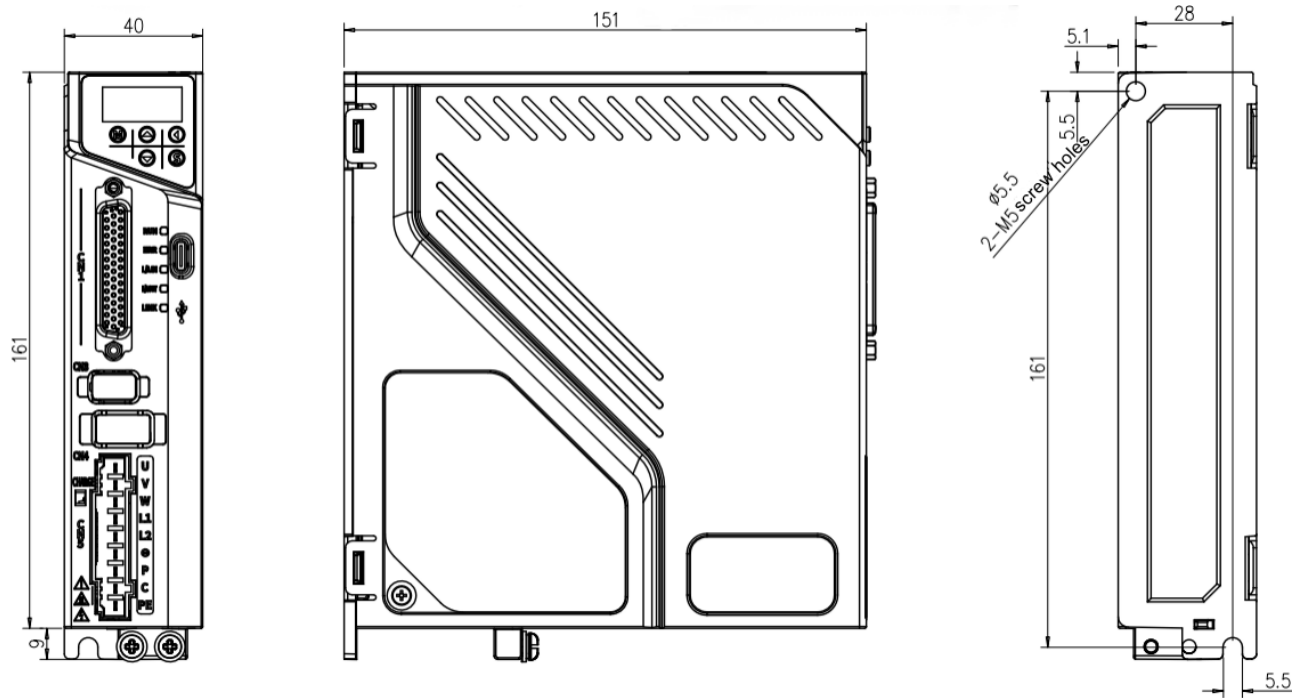

◆ The installation dimensions of Size-B (in mm) are shown below. It weighs 1 kg.

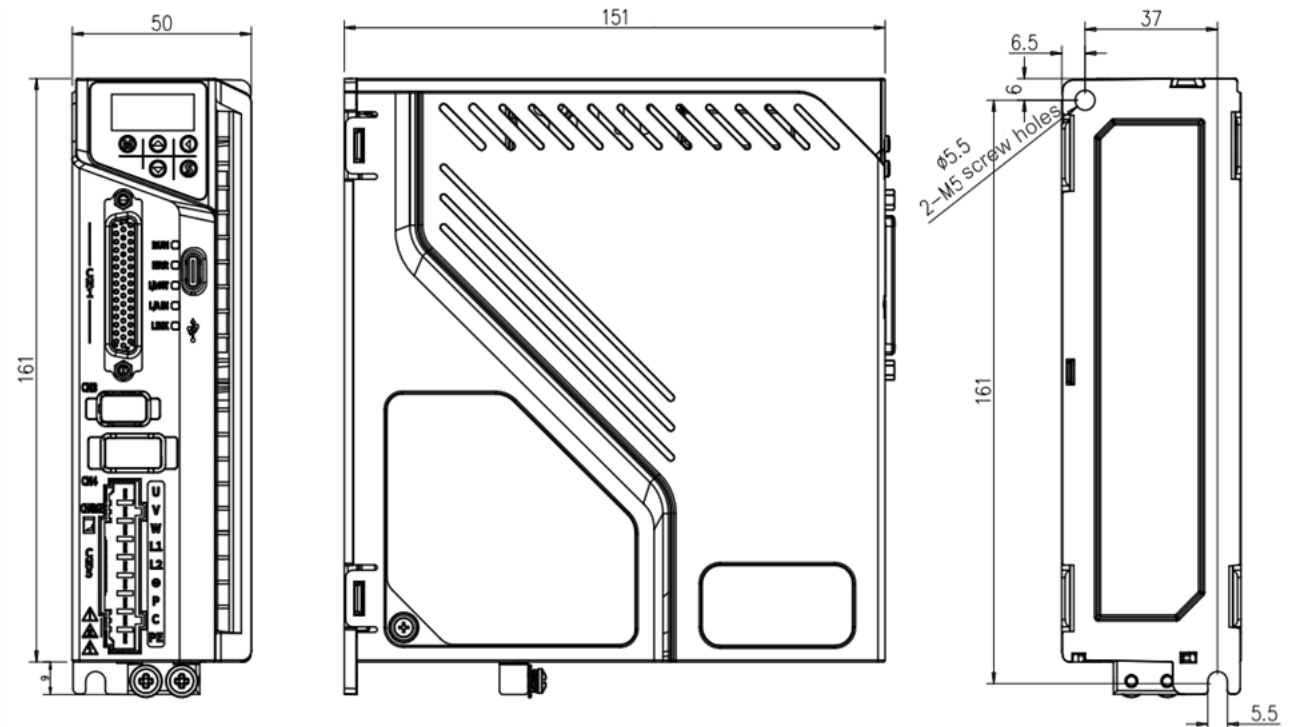

◆ The installation dimensions of Size-C (in mm) are shown below. It weighs 1.3 kg.

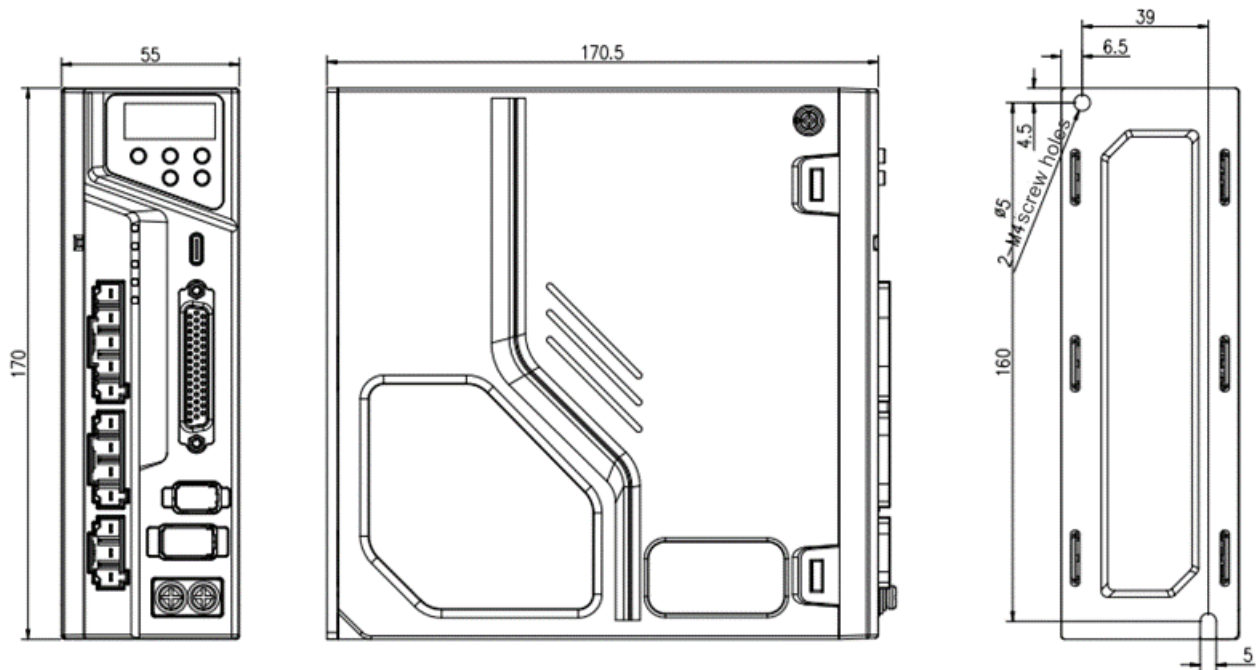

◆ The installation dimensions of Size-D (in mm) are shown below. It weighs 1.8 kg.

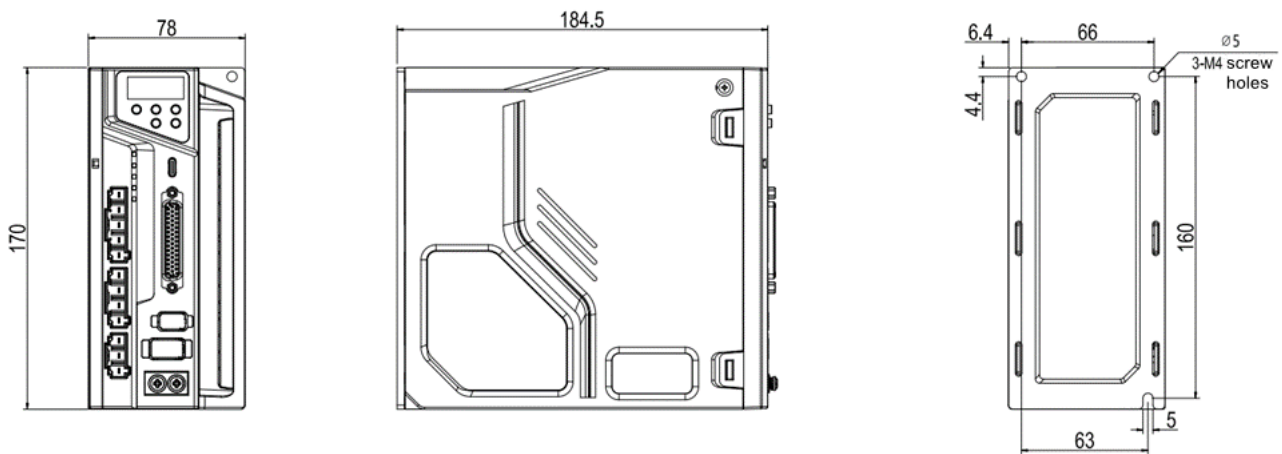

◆ The installation dimensions of Size-E (in mm) are shown below. It weighs 3.6 kg.

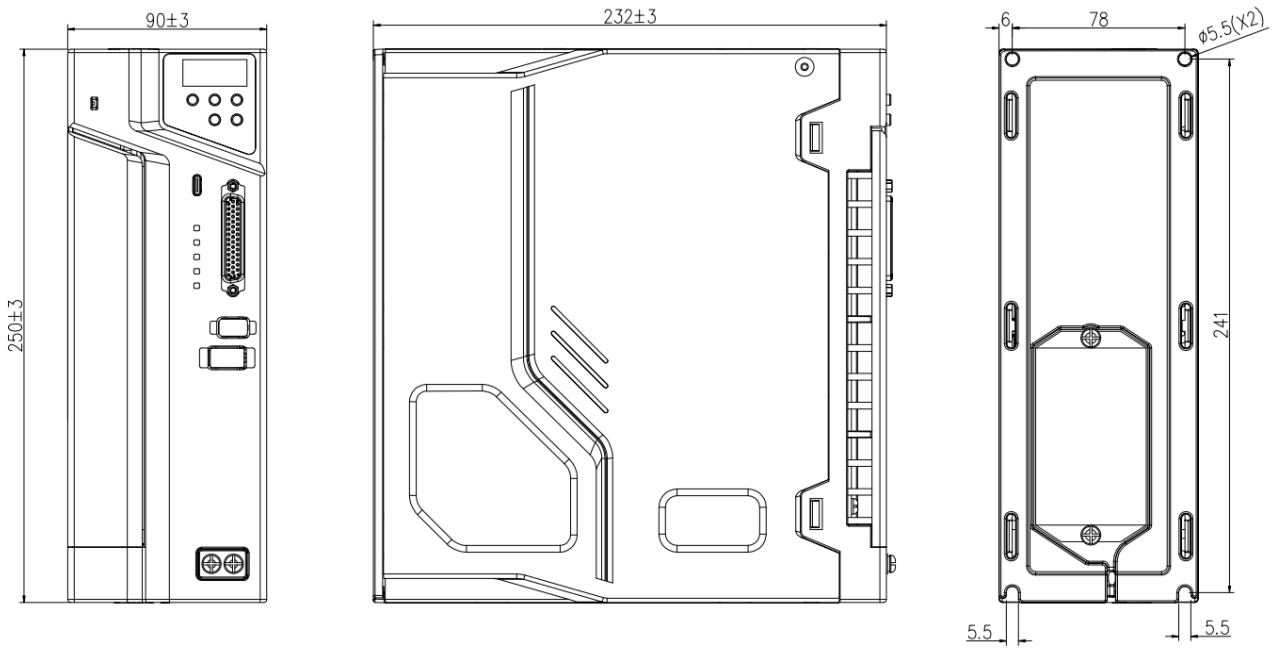

## 1.2 Servo Motors

### 1.2.1 Servo Motor Model Description

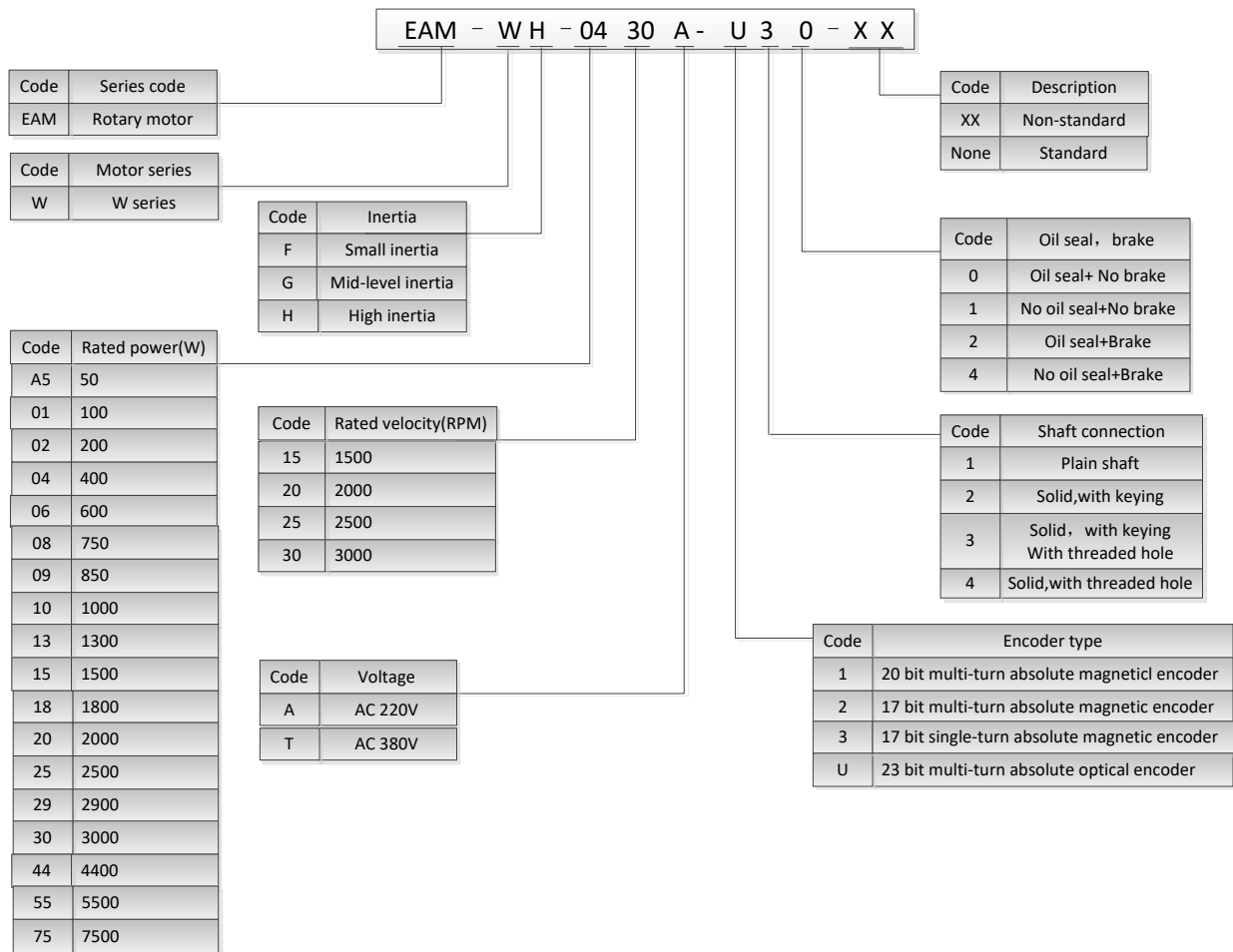

Note: If the servo motor model suffix is empty, the servo motor is a standard model.

### 1.2.2 EAM-W Series Servo Motors

#### 1.2.2.1 EAM-W Series Servo Motor Nameplate Description

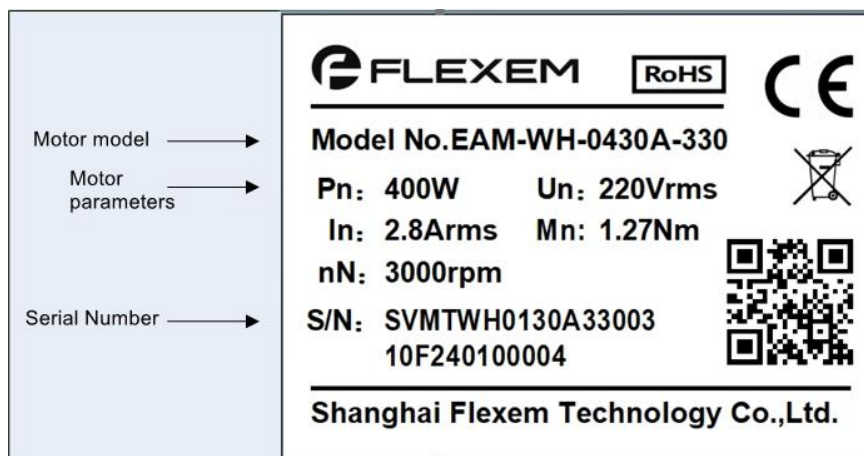

### 1.2.2.2 Mechanical Characteristic Parameters and Specifications of EAM-W Series Servo Motors

Item	Description
Duty Cycle	Continuous
Vibration Level	V15
Insulation Resistance	DC 500V, above 10M $\Omega$
Operating Ambient Temperature	-20~50 $^{\circ}$ C
Excitation Method	Permanent magnet
Installation Method	Flange type
Heat Resistance Level	Level F
Insulation Voltage	AC 1500V 1 minute (200V level) AC 1800V 1 minute (400V level)
Enclosure Protection Level	IP65
Operating Ambient Humidity	<90% (non-condensing)
Connection Method	Direct connection
Rotation Direction	Counterclockwise (CCW) when viewed from the load side under positive rotation command

### 1.2.2.3 Specifications of EAM-W Series Servo Motors

Model	Flange size (mm)	Rated power (kW)	Rated torque (N $\cdot$ m)	Maximum torque (N $\cdot$ m)	Rated current (ARMS)	Rated velocity (RPM)	Maximum velocity (RPM)	Rotor rotation inertia(10 <sup>-4</sup> kg $\cdot$ m <sup>2</sup> )	Voltage (V)
EAM-WH-A530A- $\square$ 3▲	40	50	0.16	0.48	0.6	3000	6000	0.035 (0.038)	220
EAM-WH-0130A- $\square$ 3▲	40	100	0.32	0.96	1	3000	6000	0.053 (0.056)	220
EAM-WH-0230A- $\square$ 3▲	60	200	0.64	1.92	1.4	3000	6000	0.29 (0.32)	220
EAM-WH-0430A- $\square$ 3▲	60	400	1.27	3.81	2.8	3000	6000	0.53(0.56)	220
EAM-WH-0830A- $\square$ 3▲	80	750	2.4	7.2	3.8	3000	6000	1.62(1.72)	220

Model	Flange size (mm)	Rated power (kW)	Rated torque (N·m)	Maximum torque (N·m)	Rated current (ARMS)	Rated velocity (RPM)	Maximum velocity (RPM)	Rotor rotation inertia(10 <sup>-4</sup> kg·m <sup>2</sup> )	Voltage (V)
EAM-WH-1030A-□3▲	80	1000	3.2	9.6	5.5	3000	6000	2.1(2.2)	220
EAM-WG-1230A-□3▲	110	1200	4	12	5	3000	3500	7.3(7.5)	220
EAM-WH-1530A-□3▲	110	1500	5	15	6	3000	3500	9.2(9.4)	220
EAM-WH-1830A-□3▲	110	1800	6	18	7.7	3000	3500	10.8(10.9)	220
EAM-WG-0915A-□3▲	130	850	5.39	16.17	6.9	1500	3000	10.9(12.13)	220
EAM-WG-1315A-□3▲	130	1300	8.34	25.02	10.7	1500	3000	16.9(18.13)	220
EAM-WG-1515A-□3▲	130	1500	10	25	6	1500	2000	18.8(20.28)	220
EAM-WG-1815A-□3▲	130	1800	11.5	28.7	13.8	1500	3000	21.4(22.63)	220
EAM-WG-0915T-□3▲	130	850	5.39	16.17	4	1500	3000	10.9(12.13)	380
EAM-WG-1315T-□3▲	130	1300	8.34	25.02	6	1500	3000	16.9(18.13)	380
EAM-WG-1515T-□3▲	130	1500	10	25	4	1500	2000	18.8(20.28)	380
EAM-WG-1815T-□3▲	130	1800	11.5	34.5	8.5	1500	3000	21.4(22.63)	380
EAM-WG-3030T-□3▲	130	3000	10	23	8	3000	3500	25.5(27)	380
EAM-WG-2915T-O3▲	180	2900	18.6	55.8	11.9	1500	3000	62.5(69.5)	380
EAM-WG-4415T-O3▲	180	4400	28.4	85.2	16.5	1500	3000	88.5(94.5)	380
EAM-WG-5515T-□3▲	180	5500	35	105	20.8	1500	3000	114.4(120.4)	380
EAM-WG-7515T-□3▲	180	7500	48	120	26	1500	3000	136.6(142.6)	380

Note: When □ is U: Supports 23-bit optical encoder, requires FV5-R3 drive

When □ is 3: Supports 17-bit magnetic encoder, requires FV5-R1 or FV5-R3 drive

When ▲ is 0: Motor without brake

When ▲ is 2: Motor with brake

Flange size 40mm means the size of flange mounting panel is 40mm\*40mm; flange size 60mm means the size of flange mounting panel is 60mm\*60mm; other sizes follow the same logic.

Data in brackets in the rotor inertia column is for motors with brakes, data outside brackets is for motors without brakes.

For specifications of other servo motor models, please contact Flexem technical support engineers.

### 1.2.2.4 EAM-W Series Servo Motor Installation Dimensions

◆ EAM-WG-2915T-U30 2.9kW Motor without brake installation dimensions (unit: mm)

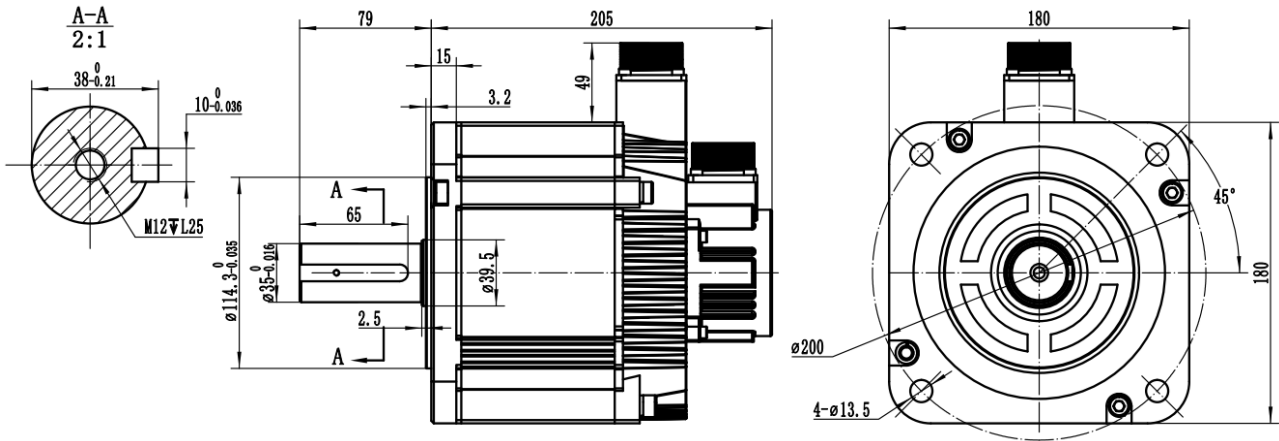

◆ EAM-WG-2915T-U32 2.9kW Motor with brake installation dimensions (unit: mm)

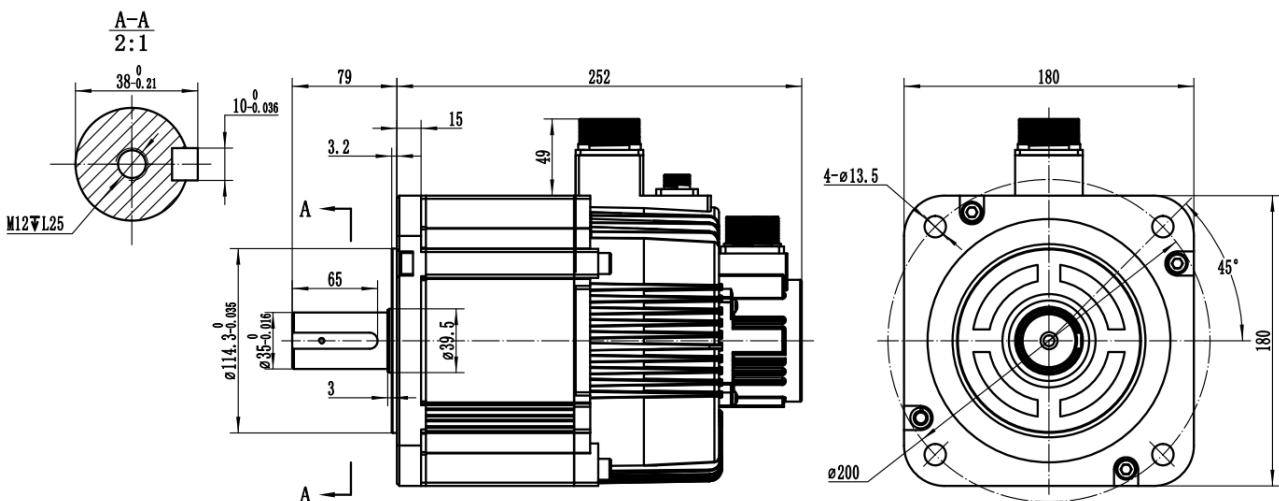

◆ AM-WG-4315T-U30 4.3kW Motor without brake installation dimensions (unit: mm)

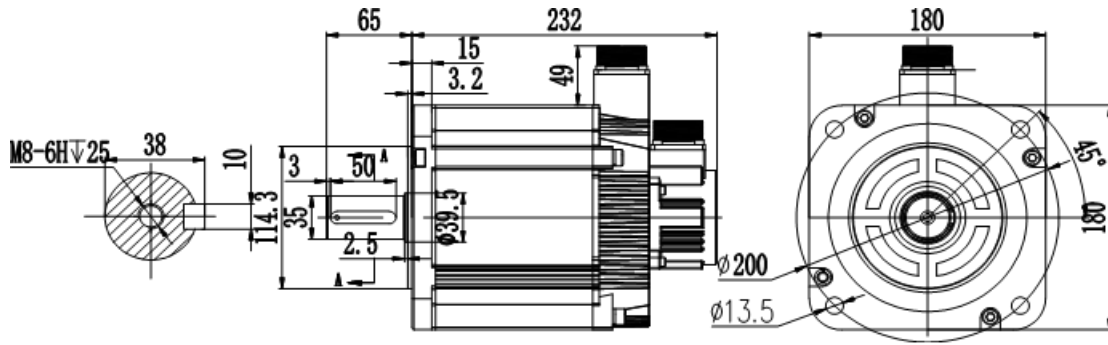

◆ EAM-WG-4315T-U32 4.3kW Motor with brake installation dimensions (unit: mm)

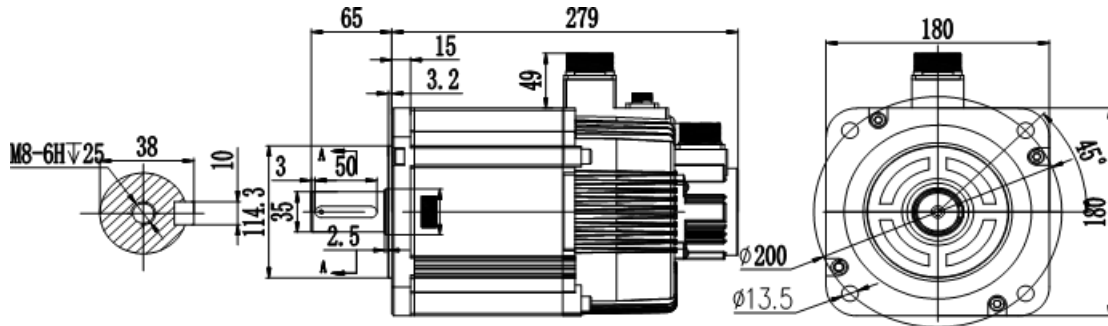

◆ EAM-WH-7515T-U30 7.5kW Motor with brake installation dimensions (unit: mm)

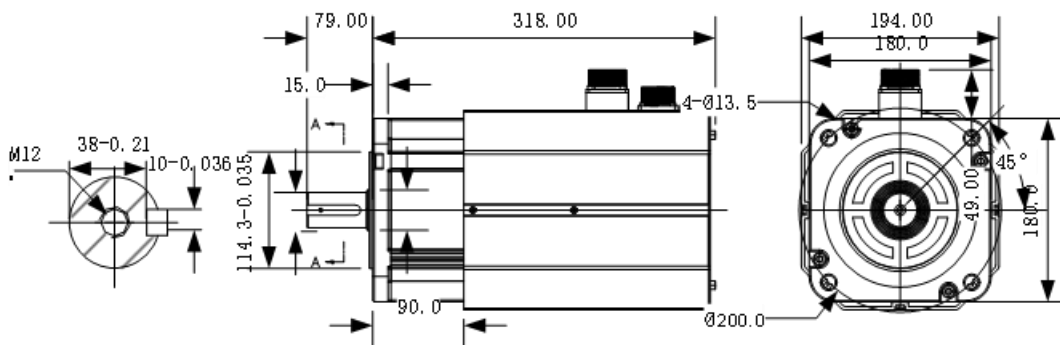

Note: For installation dimensions of other servo motor models, please contact Flexem technical support engineers.

### 1.3 Servo Drive and Servo Motor Matching Description

Flange size (mm)	Motor power	Motor model	Drive model
40	50	EAM-WH-A530A-□3 ▲	FV5-R*-*A1R1
40	100	EAM-WH-0130A-□3 ▲	FV5-R*-*A1R1
60	200	EAM-WH-0230A-□3 ▲	FV5-R*-*A1R6
60	400	EAM-WH-0430A-□3 ▲	FV5-R*-*A2R8
80	750	EAM-WH-0830A-□3 ▲	FV5-R*-*A5R5
80	1000	EAM-WH-1030A-□3 ▲	FV5-R*-*A6R0

Flange size (mm)	Motor power	Motor model	Drive model
110	1200	EAM-WG-1230A-□3▲	FV5-R*-*C7R6
110	1500	EAM-WH-1530A-□3▲	FV5-R*-*C012
110	1800	EAM-WH-1830A-□3▲	FV5-R*-*C012
130	850	EAM-WG-0915A-□3▲	FV5-R*-*C7R6
130	1300	EAM-WG-1315A-□3▲	Fv5-R*-*C012
130	1500	EAM-WG-1515A-□3▲	FV5-R*-*C7R6
130	1800	EAM-WG-1815A-□3▲	FV5-R*-*C012
130	850	EAM-WG-0915T-□3▲	FV5-R*-*T5R4
130	1300	EAM-WG-1315T-□3▲	FV5-R*-*T5R4
130	1500	EAM-WG-1515T-□3▲	FV5-R*-*T5R4
130	1800	EAM-WG-1815T-□3▲	FV5-R*-*T8R4
130	3000	EAM-WG-3030T-□3▲	FV5-R*-*T012
180	2900	EAM-WG-2915T-□3▲	FV5-R*-*T012
180	4400	EAM-WG-4415T-□3▲	FV5-R*-*T017
180	5500	EAM-WG-5515T-□3▲	Fv5-R*-*T021
180	7500	EAM-WG-7515T-□3▲	Fv5-R*-*T026

Note: When □ is U: Supports 23-bit optical encoder, requires FV5-R3 drive

When □ is 3: Supports 17-bit magnetic encoder, requires FV5-R1 or FV5-R3 drive

When ▲ is 0: Motor without brake

When ▲ is 2: Motor with brake

FV5-U3 series servo drive support motor with 17-bit magnetic encoder, motor with 23-bit optical encoder, motor with BISS-C encoder, motor with ABZ encoder etc.

Flange size (mm)	Motor power	Motor model	Drive model
40	50	EAM-WH-A530A-□3▲	FV5-U3-*A1R1
40	100	EAM-WH-0130A-□3▲	FV5-U3-*A1R1
60	200	EAM-WH-0230A-□3▲	FV5-U3-*A1R6
60	400	EAM-WH-0430A-□3▲	FV5-U3-*A2R8
80	750	EAM-WH-0830A-□3▲	FV5-U3-*A5R5
80	1000	EAM-WH-1030A-□3▲	FV5-U3-*A6R0
110	1200	EAM-WG-1230A-□3▲	FV5-U3-*C7R6
110	1500	EAM-WH-1530A-□3▲	FV5-U3-*C012

Flange size (mm)	Motor power	Motor model	Drive model
110	1800	EAM-WH-1830A-□3 ▲	FV5-U3-*C012
130	850	EAM-WG-0915A-□3 ▲	FV5-U3-*C7R6
130	1300	EAM-WG-1315A-□3 ▲	Fv5-U3-*C012
130	1500	EAM-WG-1515A-□3 ▲	FV5-U3-*C7R6
130	1800	EAM-WG-1815A-□3 ▲	FV5-U3-*C012
130	850	EAM-WG-0915T-□3 ▲	FV5-U3-*T5R4
130	1300	EAM-WG-1315T-□3 ▲	FV5-U3-*T5R4
130	1500	EAM-WG-1515T-□3 ▲	FV5-U3-*T5R4
130	1800	EAM-WG-1815T-□3 ▲	FV5-U3-*T8R4
130	3000	EAM-WG-3030T-□3 ▲	FV5-U3-*T012
180	2900	EAM-WG-2915T-□3 ▲	FV5-U3-*T012
180	4400	EAM-WG-4415T-□3 ▲	FV5-U3-*T017
180	5500	EAM-WG-5515T-□3 ▲	FV5-U3-*T021
180	7500	EAM-WG-7515T-□3 ▲	FV5-U3-*T026

## 2 Installation Operation

### 2.1 Installs the Servo Drive

Carefully read the safety instructions in Safety Precautions to avoid personal injury and equipment damage.

#### 2.1.1 Installation Location

- ◆ Please install inside a control cabinet that is not exposed to rain and direct sunlight, and ensure that no flammable materials are placed nearby. This device is not waterproof.
- ◆ Do not use this product in environments with corrosive gases or liquids.
- ◆ Do not use this product near flammable gases or materials.
- ◆ Do not install in high temperatures, humidity, dusty environments, cutting fluids, oil mist, or metal dust.
- ◆ Install in a well-ventilated, dry, dust-free places.
- ◆ Locations without vibration.
- ◆ Do not use gasoline, thinner, alcohol, acidic, or alkaline cleaners to clean the enclosure, avoid discoloration or damage to the enclosure.

#### 2.1.2 Installation Environment Conditions

Item	Description
Altitude	Below 1000m. For above 1000m, reduce the rating (reduce by 10% for every additional 500m)
Atmospheric Pressure	86kPa ~ 106kPa
Operating Temperature	0 ~ 55°C (when the ambient temperature is 40°C ~ 55°C, average load rate should not exceed 80%) (no condensation*2)
Storage Temperature*1	-20~85°C (no condensation*2)
Humidity	Below 90%RH (no condensation*2)
Vibration	5.88 m/s <sup>2</sup> (0.6G) at 10~60 Hz
Impact	19.6m/s <sup>2</sup>
IP Level	IP20
Pollution Degree	PD2

\*1: Short-term allowable temperature, including transportation factors.

\*2: Be aware that condensation may occur when the temperature drops and humidity increases.

#### 2.1.3 Installation Method and Precautions

##### 2.1.3.1 Installation Method

- ◆ This device has a vertical structure, ensure the drive is installed vertically.
- ◆ Firmly secure the drive to the mounting surface using the round mounting hole at the top and the semi-elliptical mounting hole at the bottom ((use M4 screws(SIZE-C/SIZE-D) or M5 screws (SIZE-A/SIZE-B/SIZE-E) for installation , recommended torque is 1.7~2N\*m).

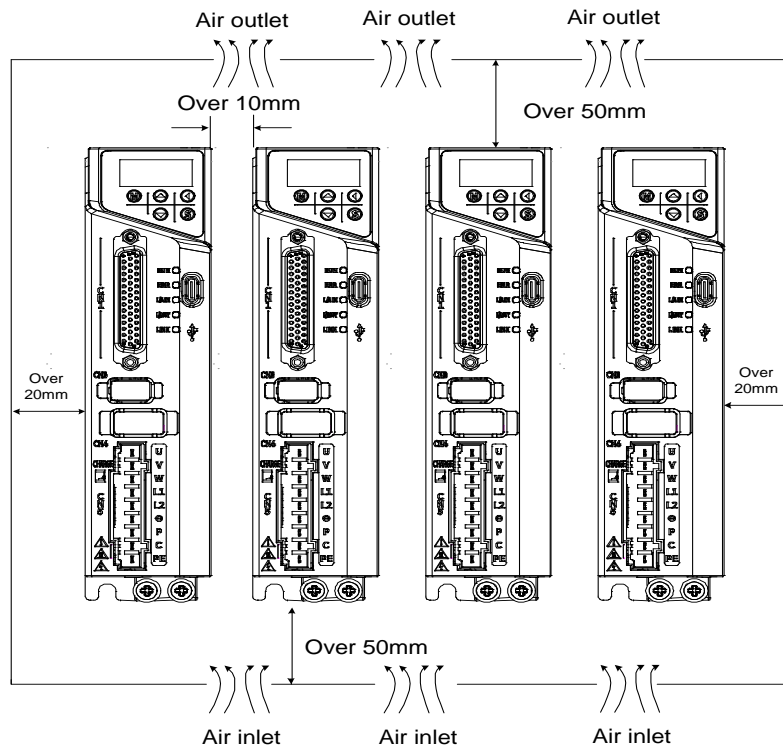

### 2.1.3.2 Heat Dissipation

- ◆ Leave sufficient space around the drive for effective cooling, as shown in the figure above, leave at least 50mm space above and below; when installed side by side, keep a horizontal interval of at least 10mm.
- ◆ Using the drive in a sealed control cabinet will cause the temperature inside the cabinet to rise abnormally. To meet the temperature requirements around the drive, consider using a cooling device.

### 2.1.3.3 Grounding

- ◆ Be sure to ground the grounding terminal. Improper grounding will not only prevent the drive from functioning properly but may also cause safety issues such as electric shock or malfunction due to interference.
- ◆ If the cabinet mounting part of the drive has a coating, remove the coating before installation to help prevent noise.

### 2.1.3.4 Wiring

- ◆ Ensure correct wiring. Incorrect wiring can cause the motor to lose control or burn out. In addition, do not let conductive materials such as wire scraps fall into the drive during installation and wiring.
- ◆ When using wires bundled in metal tubes, the allowable current of the wires may decrease due to the temperature rise, which may cause burns. Choose suitable wire after confirming the allowable current.
- ◆ When using stranded wires, organize the wires with insulated ferrules or insulated round terminals. If used without organizing, it may lead to unexpected accidents or injuries such as electric shock or leakage.
- ◆ When wiring the drive, bend the cables downward (refer to the figure below) to avoid liquids flowing into the drive along the cables, which could cause damage to the drive.

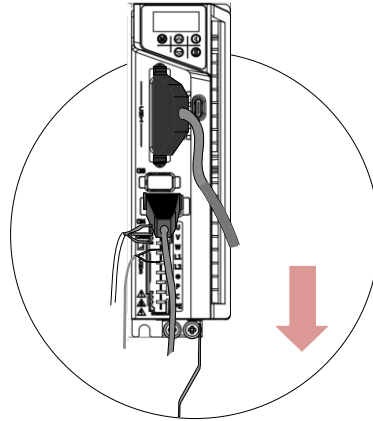

### 2.1.3.5 Precautions

- ◆ Do not apply vibrations or shocks exceeding 5.88 m/s<sup>2</sup>, do not place the drive in places with dust, metal scraps, oil mist, etc., do not place the drive in water, oil, cutting fluids, etc., do not place the drive close to flammable materials, corrosive gases (H<sub>2</sub>S, SO<sub>2</sub>, NO<sub>2</sub>, Cl<sub>2</sub>, etc.), and avoid storing or using in environments with flammable gas.
- ◆ Do not block the servo drive's suction or exhaust ports, or allow foreign objects to enter the product, as this may cause fire or product failure.
- ◆ The power must be equipped with a circuit breaker (MCCB). Additionally, the ground terminal or ground line must be grounded.
- ◆ When the power is turned on, malfunction may occur, so do not approach the motor and the machinery driven by the drive.
- ◆ When the dynamic brake operates at high speed, set a stop time of about 10 minutes.
- ◆ Ensure that the terminal screws and ground line screws are fully tightened.

## 2.2 Servo Motor Installation

### 2.2.1 Installation Location

The motor's lifespan depends on the installation location. Please install the motor in locations that meet the following conditions.

- ◆ Install indoors, away from rain and direct sunlight.
- ◆ Do not place the motor in environments with corrosive gases or liquids.
- ◆ Do not place the motor close to flammable gases or materials.
- ◆ Do not install the motor in places with high temperatures, cutting fluids, oil mist, metal dust, etc.
- ◆ Install the motor in places that are well-ventilated, without moisture, oil, or water ingress, and away from heat sources.
- ◆ Install the motor in places that are convenient for inspection and cleaning.
- ◆ Install the motor in places without vibration.

### 2.2.2 Environmental Conditions

Item	Parameter
Altitude	Below 1000m. For above 1000m, reduce rating.
Operating Temperature*1	0°C~40°C (no freezing)
Storage	-20°C~60°C (guaranteed maximum temperature: 80°C, 72 hours, no condensation)

Item	Parameter
Temperature*2	
Humidity	Below 90%RH (no condensation)
Vibration Resistance	When rotating: below 49m/s <sup>2</sup> (5G); when stopped: below 24.5m/s <sup>2</sup> (2.5G)
Shock Resistance	Below 98m/s <sup>2</sup> (10G)
IP Rating Structure	Structure IP65 (except for shaft through part and motor connector connection part)

- ◆ \*1: Ambient temperature is the temperature at 5cm from the motor.
- ◆ \*2: Short-term allowable temperature, including transportation factors.

## 2.2.3 Installation Precautions

### 2.2.3.1 Installation Direction

The motor can be installed vertically or horizontally, but the following requirements must be followed.

- ◆ Horizontal Installation

Mount the cable outlet facing downwards to prevent oil or water from entering the motor.

- ◆ Vertical Installation

When installing a motor with a gear oil, please use a motor with oil seals to prevent gear oil from entering the motor.

### 2.2.3.2 Mechanical Connection

- ◆ When installing or removing a coupling at the motor shaft end, do not use a hammer to directly strike the shaft end (doing so may damage the encoder, especially when installed on the load side of the shaft).

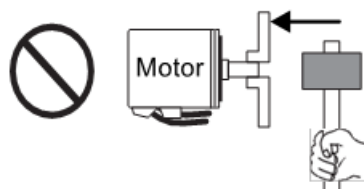

- ◆ Ensure full coaxial alignment (otherwise, it will cause vibration or damage the bearings and encoder).
- ◆ When the motor shaft operates without grounding, depending on the motor condition and installation environment, it may cause electrical corrosion of the motor bearing and excessive bearing noise. Please confirm and check.

### 2.2.3.3 Oil and Water Protection

- ◆ Do not use cables that have been immersed in oil or water.

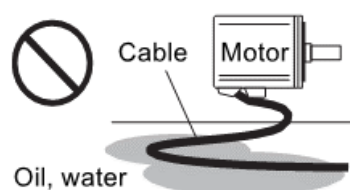

- ◆ Bend the cable outlet downward.
- ◆ Do not use the motor in environments where oil and water frequently splash on the motor body.
- ◆ When used in conjunction with a reducer, use a motor with oil seals to prevent oil from penetrating into the motor from the extended part of the shaft.

#### **2.2.3.4 Cable Stress**

- ◆ Do not let the cable outlet and connection part be stressed by bending and weight.
- ◆ When moving the motor, use relay cables that can be stored in the cable reel to minimize bending stress on the cable.
- ◆ Increase the bending radius of the cable as much as possible, ensuring it is more than 10 times the outer diameter of the cable.

#### **2.2.3.5 Wiring**

- ◆ Do not let conductive materials such as wire scraps fall into the connector during installation and wiring operation.
- ◆ Confirm the correct arrangement of connector pins during wiring.
- ◆ Fully avoid stress on the connector part caused by cable bending, which may damage the connector.
- ◆ Ensure that the motor grounding is reliably connected to the drive to prevent noise or safety issues such as malfunction due to electric shock.

# 3 Peripheral Devices and Wiring

## 3.1 Peripheral Device Wiring Diagram

### 3.1.1 SIZE-A/SIZE-B Type

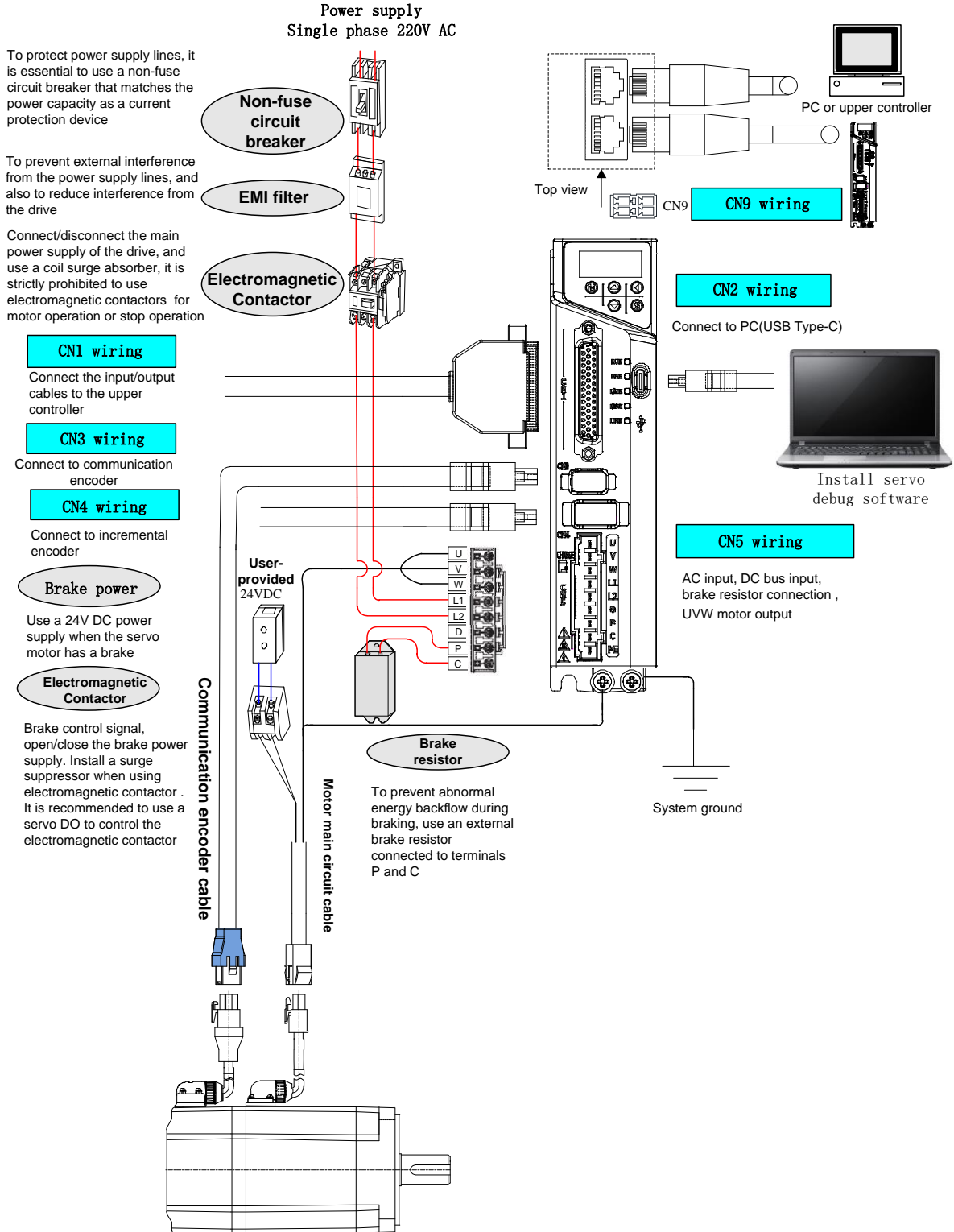

### 3.1.2 SIZE-C/SIZE-D/SIZE-E Type

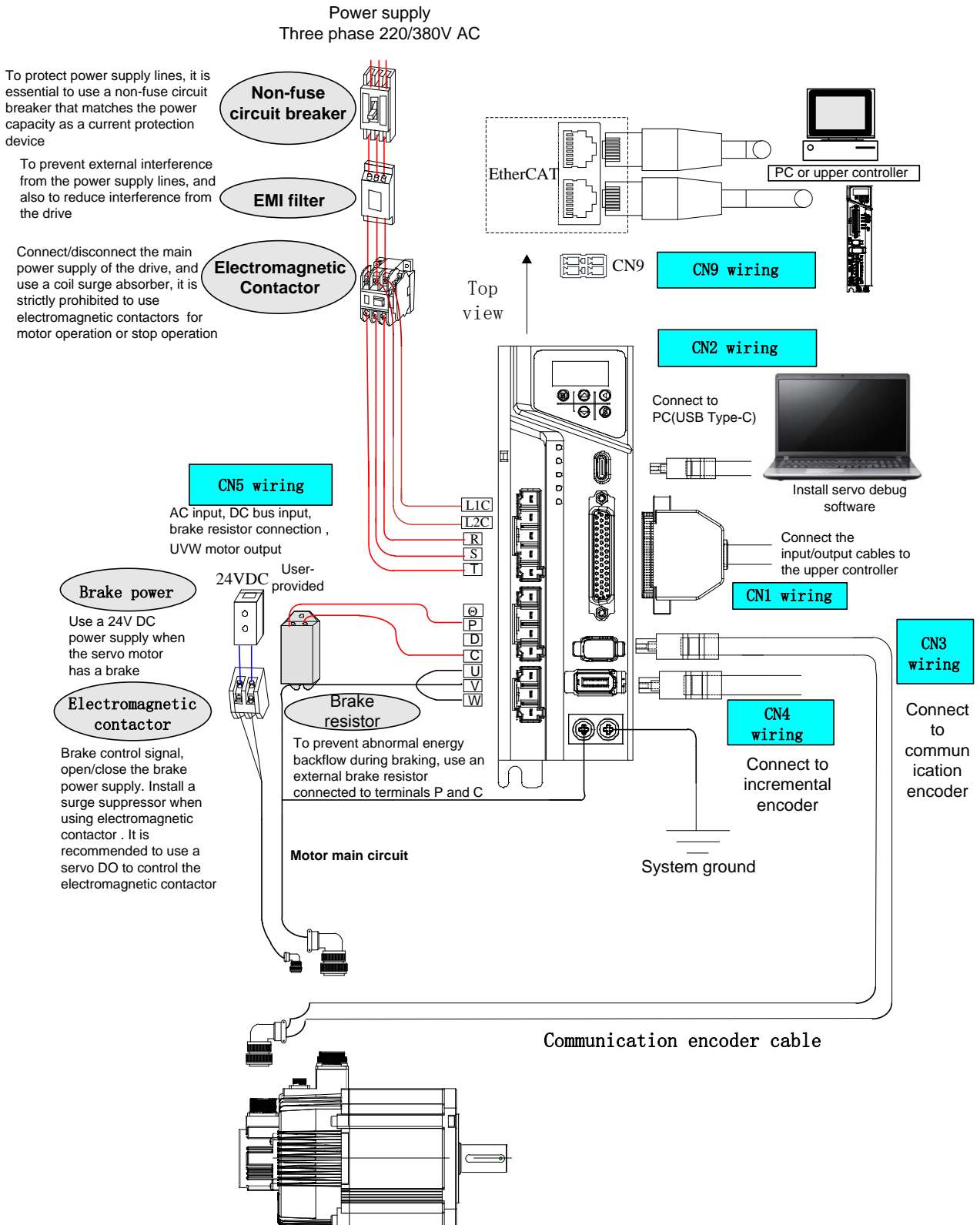

Note: The above diagram takes SIZE-C/SIZE-D for example. The terminal names and wiring methods for SIZE-E are the same as for SIZE-C/SIZE-D, but the appearance and position of the terminals differ.

### 3.1.3 System Wiring and Key Points Description

#### 3.1.3.1 SIZE-A/SIZE-B Type

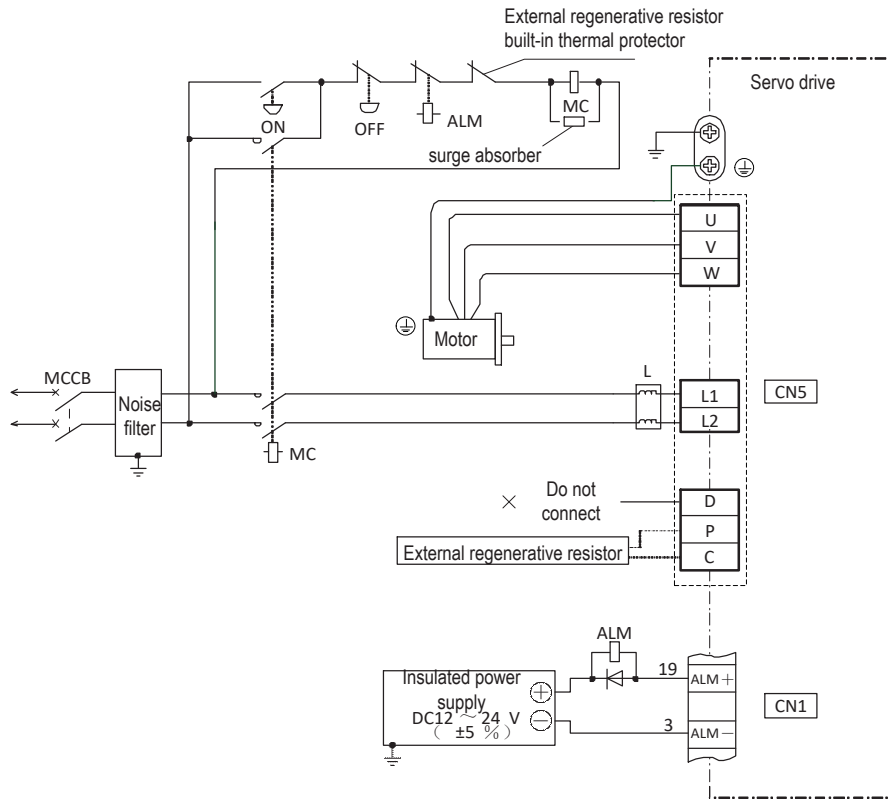

### 3.1.3.2 SIZE-C/SIZE/D/SIZE-E Type

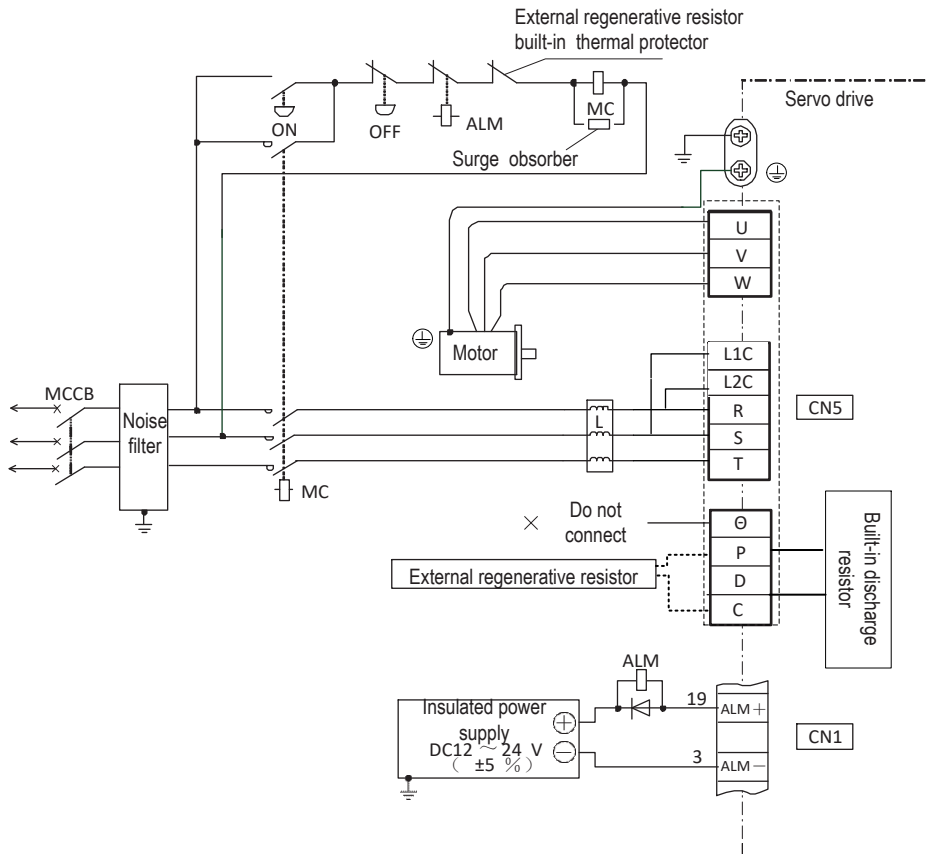

### 3.1.4 Wiring Key Points

- ◆ Wiring should be performed by an electrical engineering expert.
- ◆ Do not turn on the power before the wiring is completed to avoid electric shock accidents.
- ◆ Note that connector CN5 has high voltage, do not touch it to avoid electric shock accidents.
- ◆ Ensure that the connector plug is inserted until it makes a clicking sound.

To ensure a good electromagnetic compatibility environment, ground the system using the single-point grounding method illustrated

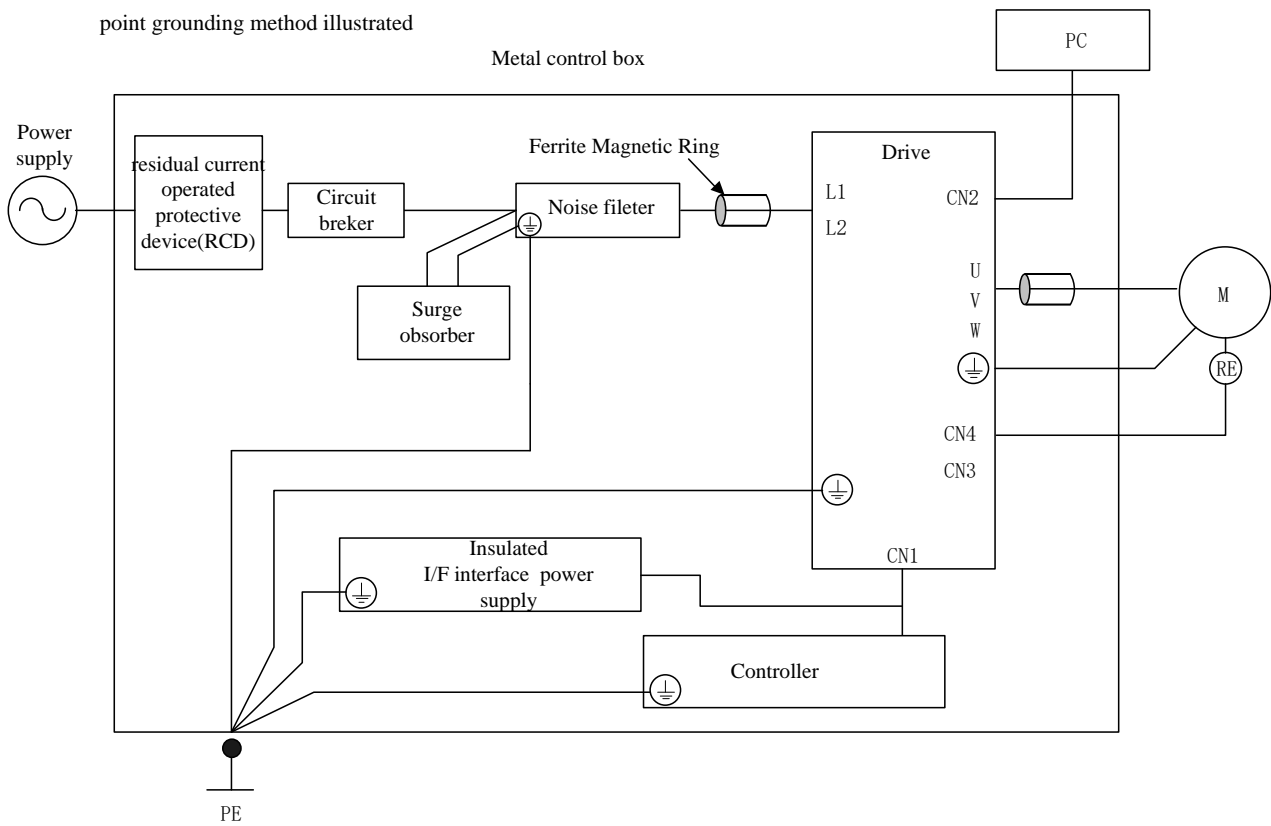

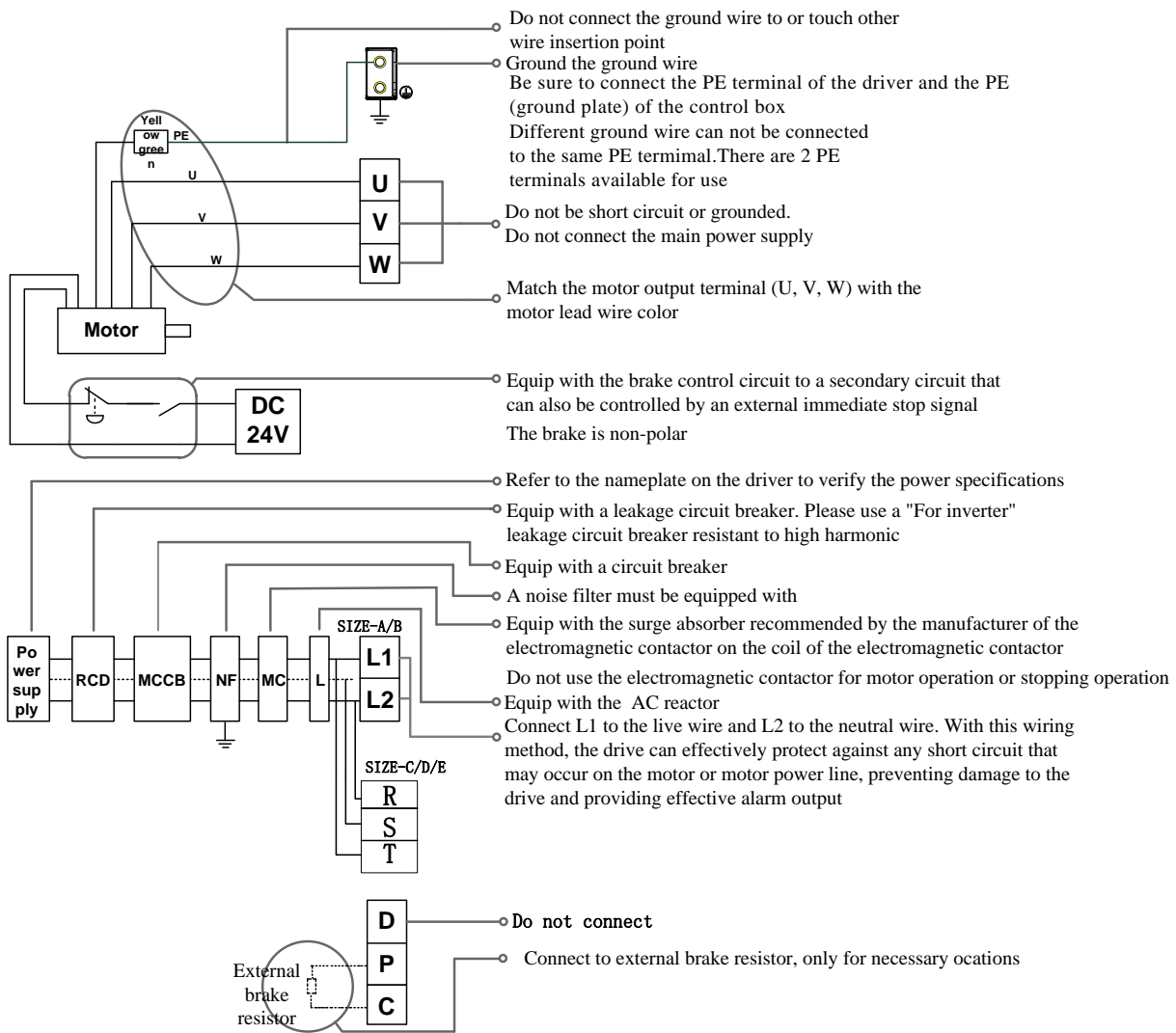

Note: The dashed line is used for three-phase input.

### 3.2 Cable and Peripheral Accessories Selection

#### 3.2.1 List of Matching Cables for Drives and Motors

Flange size(mm )	Motor	Name	Motor type	Length	Cable model
40/60/80	EAM-WH-A530A-□3▲	Power cable	Motor with brake	3m	FVL-MBA00-03-E(-T)
				5m	FVL-MBA00-05-E(-T)
				10m	FVL-MBA00-10-E(-T)
	EAM-WH-0130A-□3▲		Motor without brake	3m	FVL-MMAD0-03-E(-T)
				5m	FVL-MMA00-05-E(-T)
				10m	FVL-MMA00-10-E(-T)
	EAM-WH-0230A-□3▲	Encoder cable	Single-turn absolute encoder	3m	FVL-P1720-03-E(-T) connect to CN3
				5m	FVL-P1720-05-E(-T)
EAM-WH-0430A-□3▲				3m	FVL-P1720-03-E(-T) connect to CN3
				5m	FVL-P1720-05-E(-T)
EAM-WH-					

Flange size(mm )	Motor	Name	Motor type	Length	Cable model	
	0830A-□3▲ EAM-WH-1030A-□3▲				connect to CN3	
				10m	FVL-P1720-10-E(-T) connect to CN3	
				3m	FVL-PA720-03-E(-T) connect to CN3	
				5m	FVL-PA720-05-E(-T) connect to CN3	
				10m	FVL-PA720-10-E(-T) connect to CN3	
110/130	EAM-WG-1230A-□3▲ EAM-WH-1530A-□3▲ EAM-WH-1830A-□3▲ EAM-WG-1515A-□3▲ EAM-WG-3030A-□3▲ EAM-WH-1515T-□3▲ EAM-WG-3030T-□3▲	Power cable	Motor with brake	3m	FVL-MMC01-03-E(-T) power cable	
					FVL-MSA02-03-E(-T) brake cable	
				5m	FVL-MMC01-05-E(-T) power cable	
					FVL-MSA02-05-E(-T) brake cable	
				10m	FVL-MMC01-10-E(-T) power cable	
					FVL-MSA02-10-E(-T) brake cable	
			Motor without brake	3m	FVL-MMC01-03-E(-T)	
				5m	FVL-MMC01-05-E(-T)	
				10m	FVL-MMC01-10-E(-T)	
			110/130	EAM-WG-0915A-□3▲ EAM-WG-1315A-□3▲ EAM-WG-1815A-□3▲ EAM-WG-0915T-□3▲ EAM-WG-1315T-□3▲ EAM-WG-1815T-□3▲	Power cable	Motor with brake
5m	FVL-MBC01-05-E(-T)					
10m	FVL-MBC01-10-E(-T)					
Motor without brake	3m	FVL-MMC01-03-E(-T)				
		FVL-MMC01-05-E(-T)				
	10m	FVL-MMC01-10-E(-T)				
						FVL-MMC01-10-E(-T)
Encoder cable	Single-turn absolute encoder	3m				FVL-PI721-03-E(-T) connect to CN3

Flange size(mm )	Motor	Name	Motor type	Length	Cable model			
	1230A-□3▲ EAM-WH-1530A-□3▲ EAM-WH-1830A-□3▲ EAM-WG-0915A-□3▲ EAM-WG-1315A-□3▲ EAM-WG-1515A-□3▲ EAM-WG-1815A-□3▲ EAM-WG-0915T-□3▲ EAM-WG-1315T-□3▲ EAM-WG-1515T-□3▲ EAM-WG-1815T-□3▲ EAM-WG-3030T-□3▲			5m	FVL-PI721-05-E(-T) connect to CN3			
	10m			FVL-P1721-10-E(-T) connect to CN3				
	Multi-turn absolute encoder(with battery)			3m	FVL-PA721-03-E(-T) connect to CN3			
				5m	FVL-PA721-05-E(-T) connect to CN3			
				10m	FVL-PA721-10-E(-T) connect to CN3			
				180	EAM-WG-2915T-□3▲ EAM-WG-4415T-□3▲ EAM-WG-5515T-□3▲ EAM-WG-7515T-□3▲	Power cable	Motor with brake	3m
			FVL-MSA01-03-E(-T) brake cable					
			5m					FVL-MMC02-05-E(-T) power cable
								FVL-MSA01-05-E(-T) brake cable
			10m					FVL-MMC02-10-E(-T) power cable
	FVL-MSA01-10-E(-T) brake cable							
	Motor without brake		3m				FVL-MMC02-03-E(-T)	
			5m				FVL-MMC02-05-E(-T)	
			10m				FVL-MMC02-10-E(-T)	

Flange size(mm )	Motor	Name	Motor type	Length	Cable model
		Encoder cable	Single-turn absolute encoder	3m	FVL-PI721-03-E(-T) connect to CN3
				5m	FVL-PI721-05-E(-T) connect to CN3
				10m	FVL-PI721-10-E(-T) connect to CN3
			Multi-turn absolute encoder(with battery)	3m	FVL-PA721-03-E(-T) connect to CN3
				5m	FVL-PA721-05-E(-T) connect to CN3
				10m	FVL-PA721-10-E(-T) connect to CN3

Refer to Servo Drive and Servo Motor Matching Description for drive and motor selection.

### 3.2.2 Servo Accessories

Flange size (mm)	Accessory type		Accessory model	
40/60/80	Combined accessory for motor without brake	FVU-T10	FVU-M00	
			FVU-P00	
	Combined accessory for motor with brake	FVU-T11	FVU-M00	
			FVU-P00	
			FVU-M01	
		Power cable connector		FVU-M00
		Brake cable connector		FVU-M01
		Encoder cable AMP-9P connector		FVU-P00
	Encoder cable 1394-10P connector		FVU-P02	
	Encoder cable 1394-6P connector		FVU-P03	
110/130	Power cable connector		FVU-M02	
180	Power cable connector		FVU-M03	
180	Brake cable connector		FVU-M04	
110/130	Brake cable connector		FVU-M05	
110/130/180	Encoder cable aviation		FVU-P01	

Flange size (mm)	Accessory type	Accessory model
	connector	
Applicable to all motor models	Battery accessory	FVU-B00
Only applicable to 130 Flange size motor with brake(WG-0915, WG-1315, and WG-1815)	Power cable connector (7 pin with brake)	FVU-M06

### 3.2.3 Communication Cable Accessories

Model	Description
FVL-CN702-01-E	Communication cable between servo drive and PC
FVL-CN701-A3-E	Multi-machine parallel communication cable for servo drive(0.3m)
FVL-PE700-01-E	Connect to CN4 of Servo drive, ABZ feedback adapter cable(1m)

### 3.2.4 Control Cable Accessories

Model	Description
FVL-CA701N-01-E	Servo drive CN1 input/output signal adapter cable (1m)
FVU-C01	Servo drive CN1 terminal accessory

### 3.2.5 Options for Peripheral Electrical Components

#### 3.2.5.1 Fuse Selection Guide

To comply with the EU safety standard EN 61800-5-1, ensure that a fuse or circuit breaker is installed on the input side to prevent accidents caused by internal short circuits.

The recommended fuses are shown as the table below.

Size	Servo Drive Model	Rated Input Current (A)	Recommended Fuse		
			Manufacturer	Rated Current (A)	Model
Single phase 220V					
A	FV5-R*-NA1R1	1.6	Eaton	5	FWP-5B
	FV5-R*-NA1R6	2.3		5	FWP-5B
	FV5-R*-NA2R8	4.0		10	FWP-10B
B	FV5-R*-NA5R5	7.9	Eaton	20	FWP-20B
Three phase 220V					

Size	Servo Drive Model	Rated Input Current (A)	Recommended Fuse		
			Manufacturer	Rated Current (A)	Model
C	FV5-R*-NC7R6	5.7	Eaton	15	FWP-15B
D	FV5-R*-NC012	7.3	Eaton	20	FWP-20B
Three phase 380V					
C	FV5-R*-NT3R5	2.5	Eaton	5	FWP-5B
	FV5-R*-NT5R4	3.8		10	FWP-10B
D	FV5-R*-NT8R4	5.4	Eaton	15	FWP-15B
	FV5-R*-NT012	7.9		20	FWP-20B
E	FV5-R*-NT017	12	Eaton	35	FWP-35B
	FV5-R*-NT021	16		35	FWP-35B
	FV5-R*-NT026	21		40	FWP-40B

### 3.2.5.2 Electromagnetic Contactor Selection Guide

Refer to the peripheral unit wiring diagram for electromagnetic contactor installation details.

Refer to the table below for electromagnetic contactor selection:

Size	Servo Drive Model	Rated Input current (A)	Recommended Electromagnetic Contactor		
			Manufacturer	Rated Current (A)	Model
Single phase 220V					
A	FV5-R*-NA1R1	1.6	Schneider	9	LC1 D09
	FV5-R*-NA1R6	2.3		9	LC1 D09
	FV5-R*-NA2R8	4.0		9	LC1 D09
B	FV5-R*-NA5R5	7.9	Schneider	9	LC1 D09
Three phase 220V					
C	FV5-R*-NC7R6	5.7	Schneider	9	LC1 D09
D	FV5-R*-NC012	7.3	Schneider	9	LC1 D09
Three phase 380V					
C	FV5-R*-NT3R5	2.5	Schneider	9	LC1 D09
	FV5-R*-NT5R4	3.8		9	LC1 D09

Size	Servo Drive Model	Rated Input current (A)	Recommended Electromagnetic Contactor		
			Manufacturer	Rated Current (A)	Model
D	FV5-R*-NT8R4	5.4	Schneider	9	LC1 D09
	FV5-R*-NT012	7.9		9	LC1 D09
E	FV5-R*-NT017	12	Schneider	12	LC1 D12
	FV5-R*-NT021	16		18	LC1 D18
	FV5-R*-NT026	21		25	LC1 D25

### 3.2.5.3 Circuit Breaker Selection Guide

Refer to the peripheral unit wiring diagram for breaker installation details.

Refer to the table below for Circuit Breaker Selection Recommendations:

Size	Servo Drive Model	Rated Input Current (A)	Recommended Circuit Breaker		
			Manufacture	Rated Current (A)	Model
Single phase 220V					
A	FV5-R*-NA1R1	1.6	Schneider	4	OSMC32N2D4
	FV5-R*-NA1R6	2.3		4	OSMC32N2D4
	FV5-R*-NA2R8	4.0		6	OSMC32N2D6
B	FV5-R*-NA5R5	7.9	Schneider	16	OSMC32N2D16
Single phase 220V					
C	FV5-R*-NC7R6	5.7	Schneider	10	OSMC32N2D10
D	FV5-R*-NC012	7.3	Schneider	16	OSMC32N2D16
Single phase 380V					
C	FV5-R*-NT3R5	2.5	Schneider	4	OSMC32N2D4
	FV5-R*-NT5R4	3.8		6	OSMC32N2D6
D	FV5-R*-NT8R4	5.4	Schneider	10	OSMC32N2D10
	FV5-R*-NT012	7.9		16	OSMC32N2D16
E	FV5-R*-NT017	12	Schneider	20	OSMC32N2D20
	FV5-R*-NT021	16		25	OSMC32N2D25
	FV5-R*-NT026	21		32	OSMC32N2D32

If the equipment requires a residual current device (RCD), follow the selection criteria below:

- ◆ The drive may generate DC leakage current in the protective conductor. Be sure to use a Type B Residual Current Device (RCD).
- ◆ A certain amount of high-frequency leakage current will be generated during drive operation. To prevent RCD malfunction, select an RCD with an operating current of at least 100mA for each drive.
- ◆ When multiple drives are connected in parallel to share an RCD, select an RCD with an operating current of at least 300mA.
- ◆ It is recommended to use RCDs from brands such as Chint, Schneider, and others.

### 3.2.5.4 AC Input Reactor Selection Guide

The AC input reactor is primarily designed to reduce harmonics in the input current and is configured as an option. When the application environment requires higher levels of harmonic reduction, an external reactor can be installed.

The recommended AC input reactors are shown in the table below:

Size	Servo Drive Model	Rated Input Current (A)	Recommended AC Input Reactor		
			Manufacture	Inductance (mH)	Model
Three phase 220V					
C	FV5-R*-NC7R6	5.7	Huayin (Shanghai)	5	SHD-800-9
D	FV5-R*-NC012	7.3	Huayin (Shanghai)	5	SHD-800-9
Three phase 380V					
C	FV5-R*-NT3R5	2.5	Huayin (Shanghai)	5	SHD-800-9
	FV5-R*-NT5R4	3.8		5	SHD-800-9
D	FV5-R*-NT8R4	5.4	Huayin (Shanghai)	5	SHD-800-9
	FV5-R*-NT012	7.9		5	SHD-800-9
E	FV5-R*-NT017	12	Huayin (Shanghai)	3	SHD-800-10
	FV5-R*-NT021	16		1.45	SHD-800-13
	FV5-R*-NT026	21		1.45	SHD-800-13

The size specifications for AC input reactors are shown in the table below.

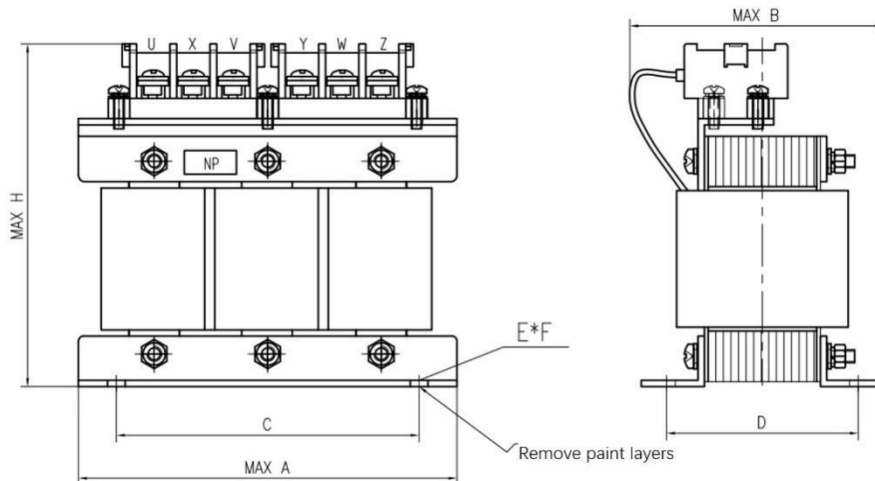



Model	Input Current (A)	Inductance (mH)	A (mm)	B (mm)	H (mm)	C×D (mm)	ΦE×F (mm)
SHD-800-9	8	5	175	150	175	120×90	8×12
SHD-800-10	12	3	175	150	175	120×90	8×12
SHD-800-13	21	1.45	230	180	220	150×110	8×12

### 3.2.5.5 EMC Input Filters

In order to make the product meet the requirements of the ENIEC 61800-3 standard for radiated and conducted emissions, an external EMC filter is required.

The EMC filters available for this product are Schaffner's FN2090 and FN3258 series, and the EMC filter profiles are as follows:

Model		Appearances
Schaffner	FN2090 Series	
	FN3258 Series	

Please select according to the rated input current of this product as the table below:

Size	Servo Drive Model	Rated Input Current (A)	Recommended EMC Input Filters	
			Manufacture	Model
Single phase 220V				
A	FV5-R*-NA1R1	1.6	Schaffner	FN2090-3-06
	FV5-R*-NA1R6	2.3		FN2090-3-06
	FV5-R*-NA2R8	4.0		FN2090-4-06

Size	Servo Drive Model	Rated Input Current (A)	Recommended EMC Input Filters	
			Manufacture	Model
B	FV5-R*-NA5R5	7.9	Schaffner	FN2090-8-06
Three phase 220V				
C	FV5-R*-NC7R6	5.7	Schaffner	FN3258-7-44
D	FV5-R*-NC012	7.3	Schaffner	FN3258-16-44
Three phase 380V				
C	FV5-R*-NT3R5	2.5	Schaffner	FN3258-7-44
	FV5-R*-NT5R4	3.8		FN3258-7-44
D	FV5-R*-NT8R4	5.4	Schaffner	FN3258-7-44
	FV5-R*-NT012	7.9		FN3258-16-44
E	FV5-R*-NT017	12	Schaffner	FN3258-16-44
	FV5-R*-NT021	16		FN3258-16-44
	FV5-R*-NT026	21		FN3258-30-44

Schaffner FN 2090 Series Filter Dimensions Description:

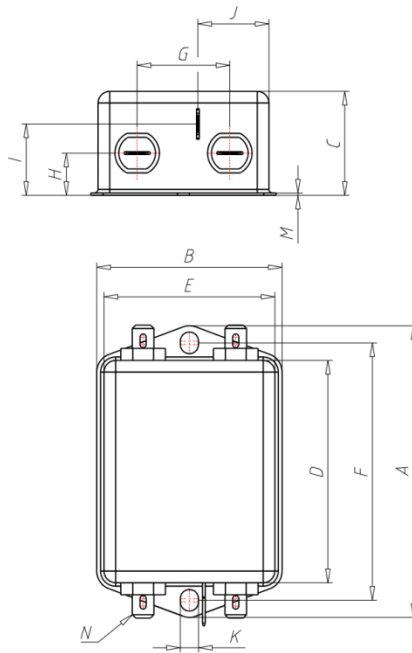

Unit: mm

Input Current (A)	A	B	C	D	E	F	G	H	I	J	K	M	N
4	85	54	30.3	64.8	49.8	75	27	12.3	20.8	19.9	5.3	0.7	6.3 × 0.8
6	85	54	30.3	64.8	49.8	75	27	12.3	20.8	19.9	5.3	0.7	6.3 × 0.8
8	113.5	57.5	45.4	94	56	103	25	12.4	32.4	15.5	4.4	1	6.3 × 0.8

Schaffner FN 3258 Series Filter Dimensions Description:

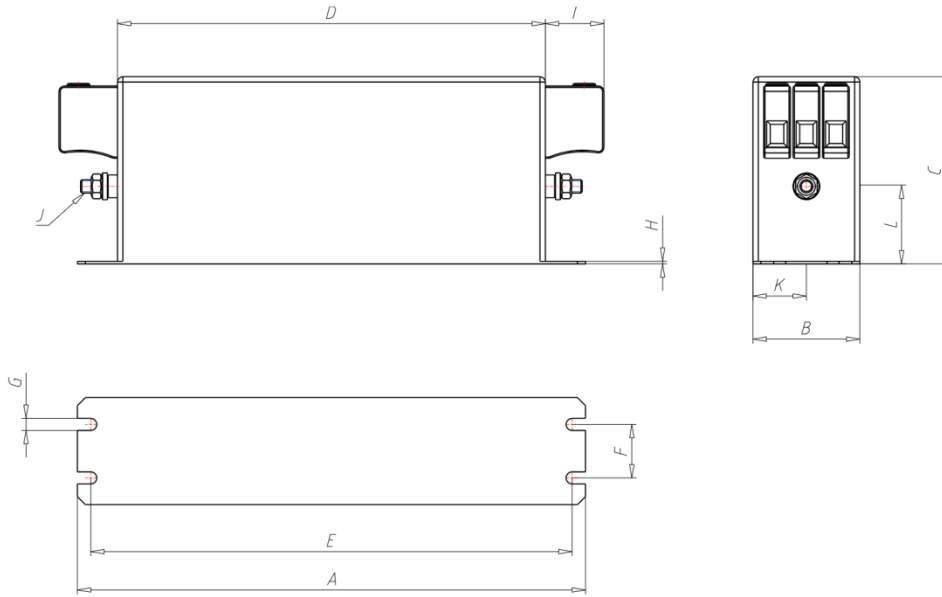

Input Current (A)	A (mm)	B (mm)	C (mm)	D (mm)	E (mm)	F (mm)	G (mm)	H (mm)	I (mm)	J	K (mm)	L (mm)
7	190	40	70	160	180	20	4.5	1	22	M5	20	29.5
16	250	45	70	220	235	25	5.4	1	22	M5	22.5	29.5
30	270	50	85	240	255	30	5.4	1	25	M5	25	39.5

### 3.2.5.6 Magnetic rings

Magnetic rings installed on the input side can suppress the noise entering the drive in the power supply system, while magnetic rings installed on the output side are mainly used to reduce the electromagnetic interference from the drive to the outside world, and can also reduce the bearing current, please try to place them as close as possible to the drive when installing magnetic rings.

For leakage current problems and other signal line interference problems in some applications, it is recommended to use amorphous magnetic rings for suppression. Amorphous magnetic rings have a very high permeability below 1 MHz and are particularly effective in suppressing drive interference.

Two sizes of amorphous magnetic rings are available for user selection:

Material	Size (OD*ID*HT) (mm)	Appearance
Amorphous alloys	50×80×20	

Material	Size (OD*ID*HT) (mm)	Appearance
Amorphous alloys	64×40×20	

### 3.3 CN1 Connector Wiring

### 3.3.1 Definition of CN1 Connector Terminals

◆ Terminals of SIZE-A/SIZE-B type

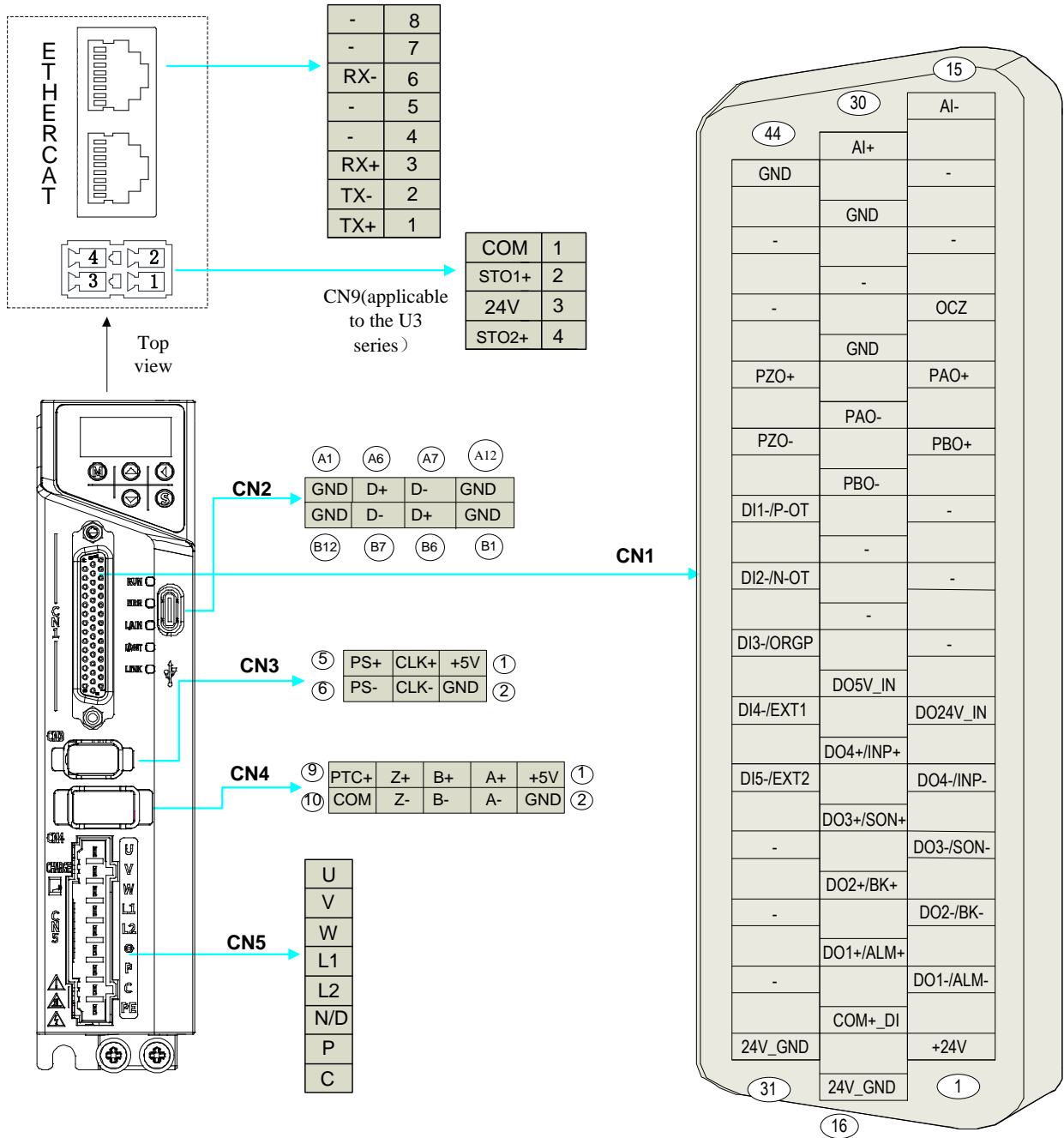

◆ Terminals of SIZE-C/SIZE-D/SIZE-E type

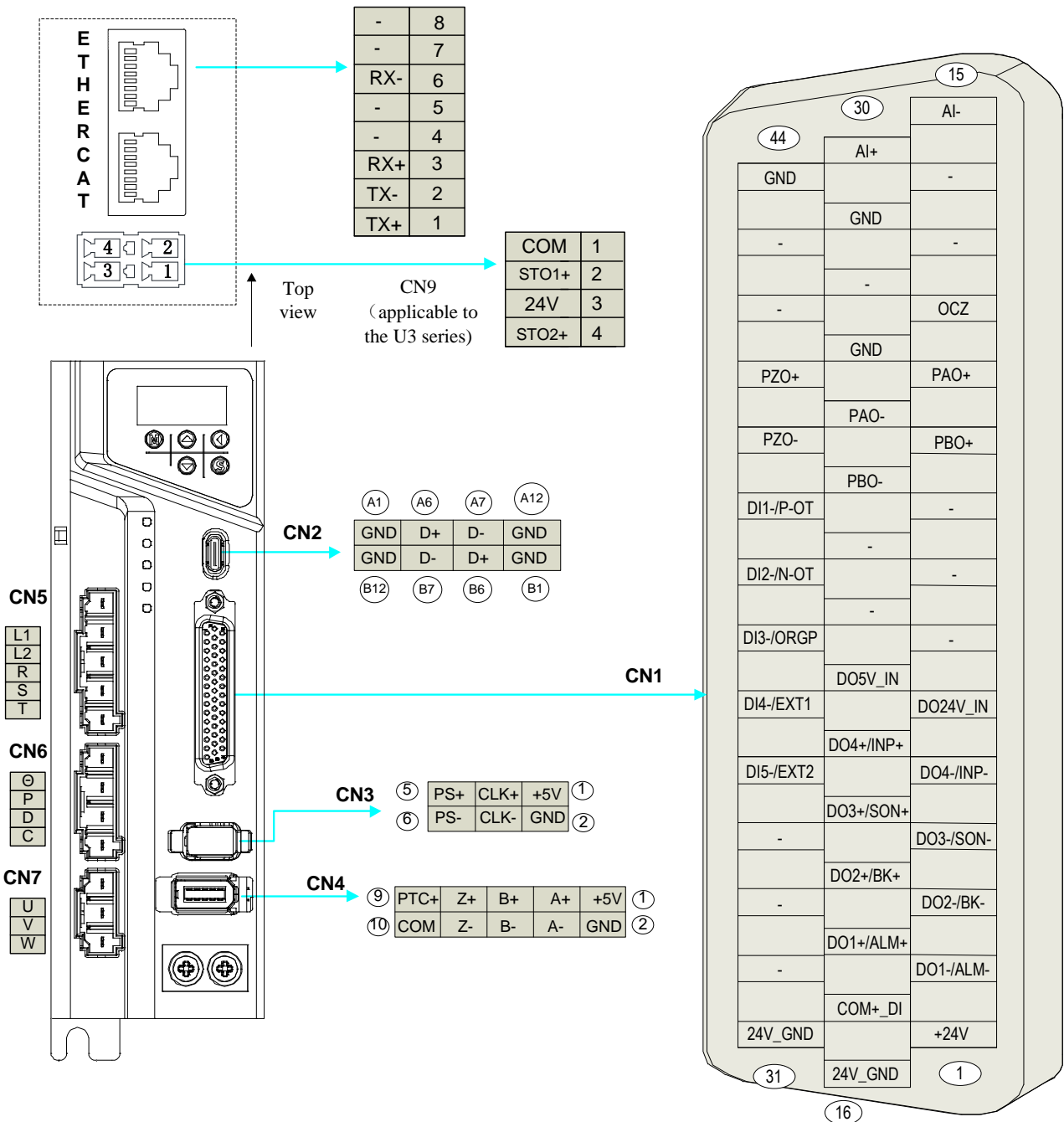

Note: The above diagram takes SIZE-C/SIZE-D as an example. The terminal names and wiring methods for SIZE-E are the same as for SIZE-C/SIZE-D, but the appearance and position of the terminals differ.

For CN1 pins, please refer to the table below.

Pin Number	Name	Abbreviation	Description
1	Internal 24V Power Positive	+24V	Limited to internal DI and pulse input pull-up usage, not for powering external relays, brakes, etc.
2	Digital Output 1 (Negative)	DO1-	Digital output has configurable functions and output logic according to user requirements. When wiring, if the

Pin Number	Name	Abbreviation	Description
3	Digital Output 2 (Negative)	DO2-	relay receives the signal, a freewheel diode needs to be added; if the optocoupler receives the signal, a current-limiting resistor needs to be connected. Incorrect wiring can cause burn damage to the DO port.
4	Digital Output 3 (Negative)	DO3-	
5	Digital Output 4 (Negative)	DO4-	
6	High-Speed DO Power Supply 24V Input	DO24V_IN	Supplies 24V DO power to this pin when the high-speed DO is at 24V logic level.
10	Frequency Division Output Phase B (Positive)	PBO+	The number of pulses per motor revolution is set by P02.03, the actual number of frequency division outputs is 4*P02.03(4 times frequency multiplication).
11	Frequency Division Output Phase A (Positive)	PAO+	
12	Phase Z Open Collector Output	OCZ	The motor outputs one Z pulse per revolution, the level is set by P02.05, and the output is open collector.
15	high-precision Analog Input Negative (applicable to the U3 series)	AI-	Negative terminal for high-precision analog input channel, connected to pin 30(applicable to the U3 series).
16	24V Reference Ground	24V_GND	Internal 24V power reference ground.
17	DI Common Input	COM+_DI	When using internal 24V power for DI, connect this pin to the internal 24V pin (1).
18	Digital Output 1 (Positive)	DO1+	Digital output has configurable functions and output logic according to user requirements. When wiring, if the relay receives the signal, a freewheel diode needs to be added; if the optocoupler receives the signal, a current-limiting resistor needs to be connected. Incorrect wiring can cause burn damage to the DO port.
19	Digital Output 2 (Positive)	DO2+	
20	Digital Output 3 (Positive)	DO3+	
21	Digital Output 4 (Positive)	DO4+	
22	High-Speed DO Power Supply 5V Input	DO5V_IN	Supplies 5V DO power to this pin when the high-speed DO is at 5V logic level(applicable to the U3 series) .
25	Frequency Division Output Phase B (Negative)	PBO-	The number of pulses per motor revolution is set by P02.03, the actual number of frequency division outputs is 4*P02.03(4 times frequency multiplication).
26	Frequency Division Output Phase A (Negative)	PAO-	
27	Signal Ground	GND	When the pulse command input is differential, connect

Pin Number	Name	Abbreviation	Description
			this signal ground to the upper computer signal ground. For pulse division output signal ground, connect this signal ground to the upper computer signal ground.
29	Signal Ground	GND	Signal reference ground.
30	High-precision Analog Input Positive (applicable to the U3 series)	AI+	High-precision Analog input positive, connected to pin 15 (applicable to the U3 series).
31	Internal 24V Power Reference Ground	24V_GND	Internal 24V power reference ground.
35	Digital Input 5	DI5-	Digital input has configurable functions and input logic according to user requirements. When wiring, select internal 24V or external 24V based on conditions, and select PNP or NPN type with corresponding wiring.
36	Digital Input 4	DI4-	
37	Digital Input 3	DI3-	
38	Digital Input 2	DI2-	
39	Digital Input 1	DI1-	
40	Frequency Division Output Phase Z (Negative)	PZO-	The motor outputs one Z pulse per revolution, the level is set by P02.05, outputting a differential 5V signal.
41	Frequency Division Output Phase Z (Positive)	PZO+	
44	Signal Ground	GND	Signal reference ground.

### 3.3.2 Connection to the Upper Controller

For typical wiring examples of connector CN1, please refer to the figure below.

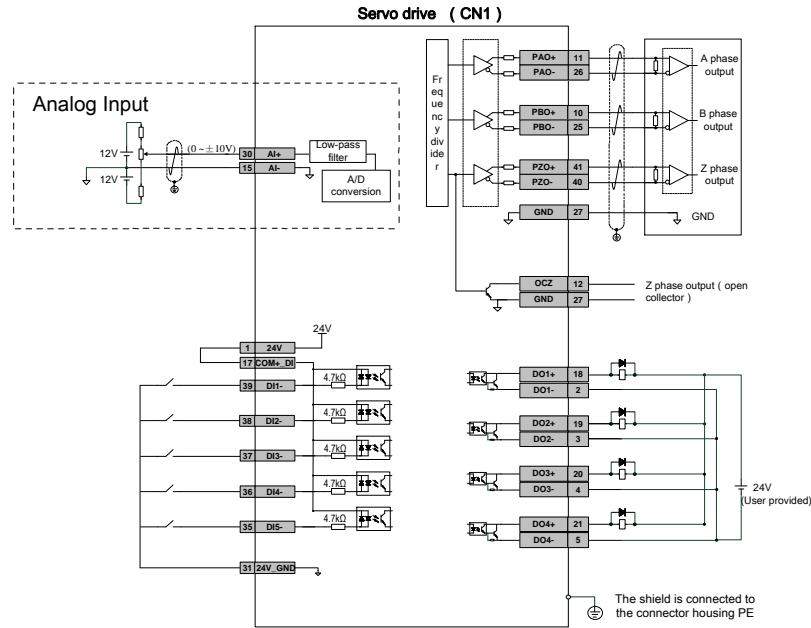

### 3.3.3 Connection of Control Input Signal

Symbol	Function	Connector Number	Pin	Description
DI1	Home position signal(default)	39		Home position signal
DI2	Positive over travel(default)	38		Positive position limit
DI3	Negative over travel(default)	37		Negative position limit
DI4	Probe 1 (default)	36		Position latching 1
DI5	Probe 2(default)	35		Position latching 2
+24V	+24V	1		Internal 24V power, voltage range +20~28V, max output current 200mA
24V_GND	Reference ground	31 or 16		
COM+_DI	COM+ for DIs	17		Power input terminal (12V~24V)

takes DI1 as an example, the connection methods for other DIs are the same.

- ◆ When the upper-level device has relay output

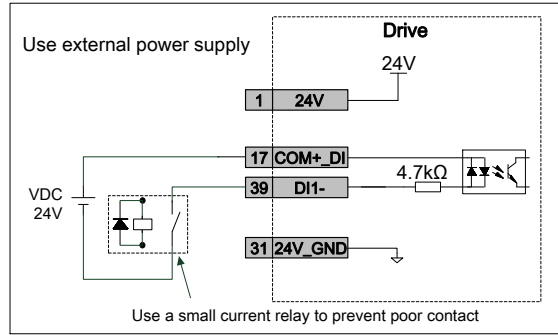
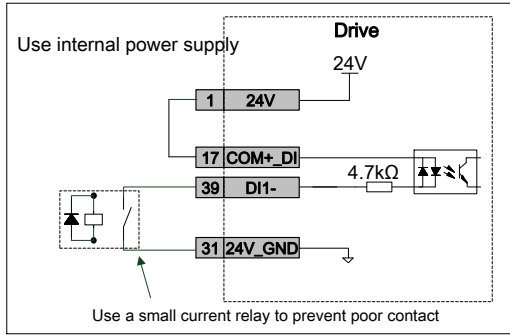

◆ When the upper-level device has NPN open collector output

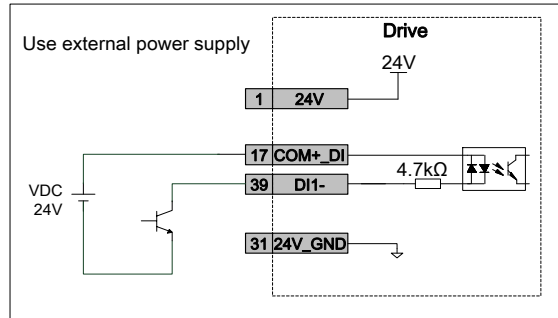
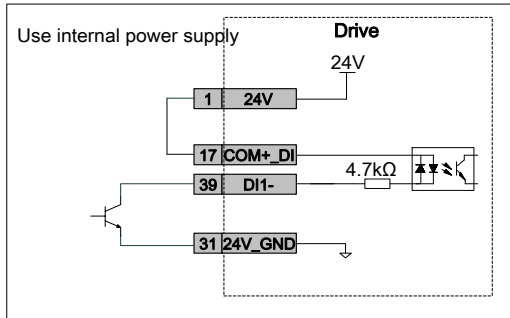

◆ When the upper-level device has PNP open collector output

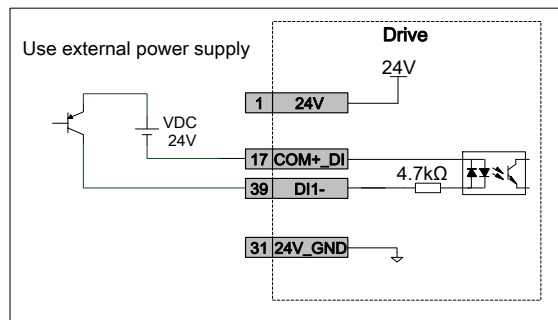
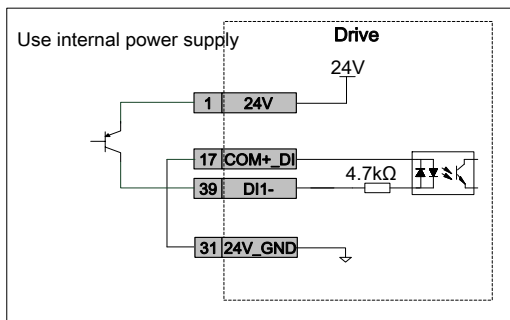

Note: Mixed use of PNP and NPN inputs is not supported.

### 3.3.4 Connection of Analog Command Input Signal (applicable to the U3 series)

Symbol	Connector Pin Number	Description
AI+	30	High-precision analog input signal positive terminal, resolution 16-bit, input voltage: -10V~+10V.
AI-	15	High-precision analog input negative terminal.

The command corresponding to the analog input voltage is set by the P03.47 and P03.4C.

Maximum allowable input voltage range: -10V~+10V;

A/D conversion resolution: 16-bit;

Input impedance: greater than 10kΩ.

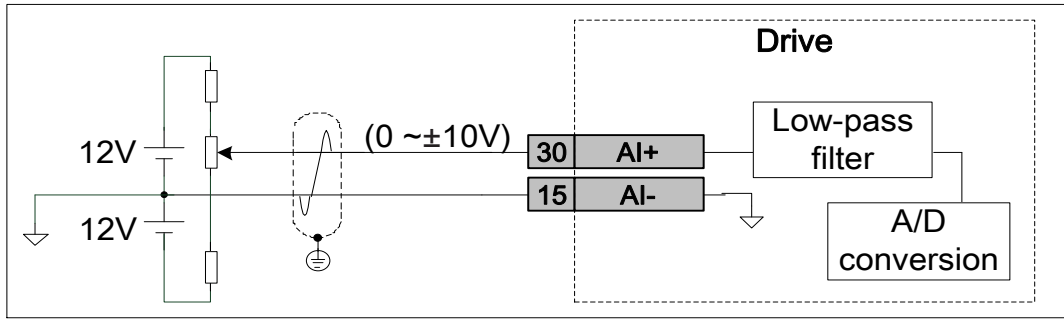

### 3.3.5 Connection of Control Output Signal

Symbol	Connector Number	Pin	Description
DO1+	18		Alarm output signal
DO1-	2		
DO2+	19		Brake signal
DO2-	3		
DO3+	20		DDR non-standard position 2 output
DO3-	4		
DO4+	21		DDR non-standard position 3 output
DO4-	5		

Takes DO1 and DO4 as examples, the connection methods for other DOs are the same.

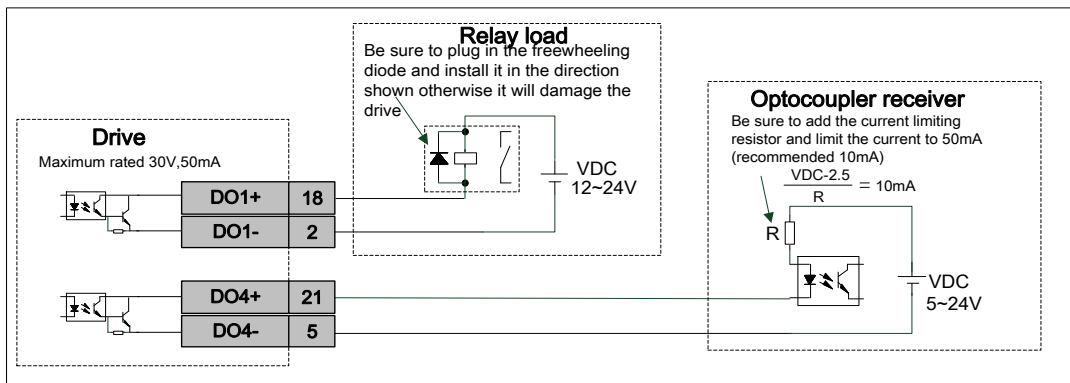

High-speed DO connection method (applicable to the U3 series)

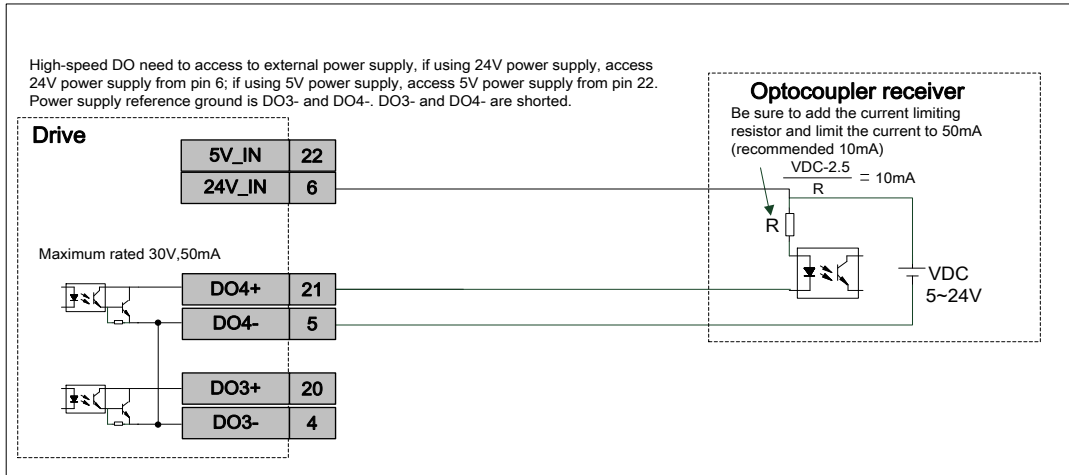

### 3.3.6 Connection of Frequency Division Pulse Output Signal

Symbol	Connector Number	Pin	Description
PAO+	11		Phase A frequency division output signal +
PAO-	26		Phase A frequency division output signal -
PBO+	10		Phase B frequency division output signal +
PBO-	25		Phase B frequency division output signal -
PZO+	41		Phase Z frequency division output signal +
PZO-	40		Phase Z frequency division output signal -
OCZ	12		Phase Z open collector output signal
GND	27		Phase Z open collector output signal reference ground

The drive provides two types of interfaces: a differential drive interface and a phase Z pulse open collector output interface.

#### 3.3.6.1 Differential Driver Output

The divided encoder signal outputs (Phase A, Phase B, Phase Z) are differentially output through a long-line drive.

When using a long-line receiver on the upper device side, be sure to install a terminal resistor (recommended around 330 Ω) at the input of the long-line receiver. When using a photoelectric coupler circuit for reception, please use a high-speed optocoupler and limit the line current to be within 20mA.

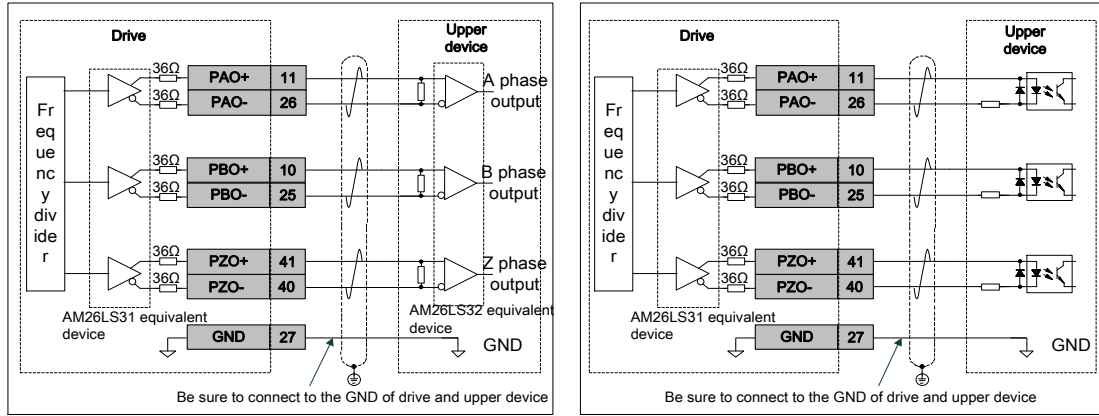

### 3.3.6.2 Open Collector Output

This interface is an open collector interface for the phase Z frequency division output signal of the encoder, which is a non-insulated interface.

Due to the relatively narrow pulse width of the phase Z signal, please use a high-speed photoelectric coupler to receive the signal on the upper device side.

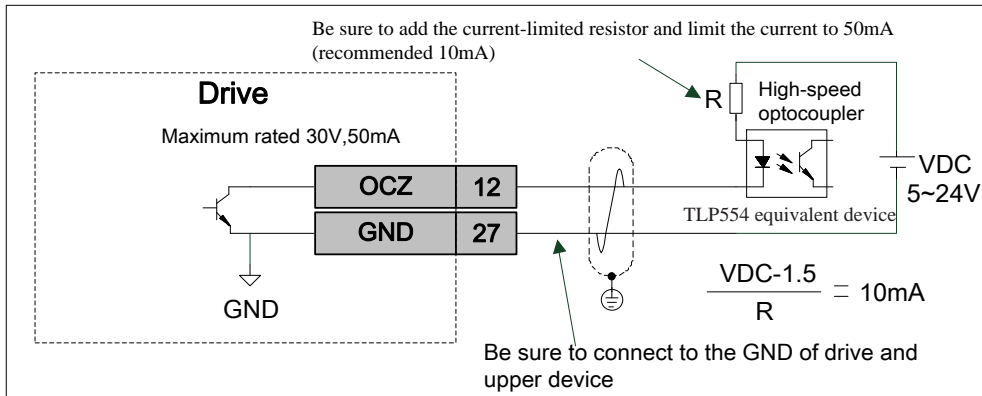

### 3.3.7 Connection of Brake Signal

Symbol	Function	Connector Pin Number	Description
DO2+	Blk+	19	Brake signal
DO2-	Blk-	3	

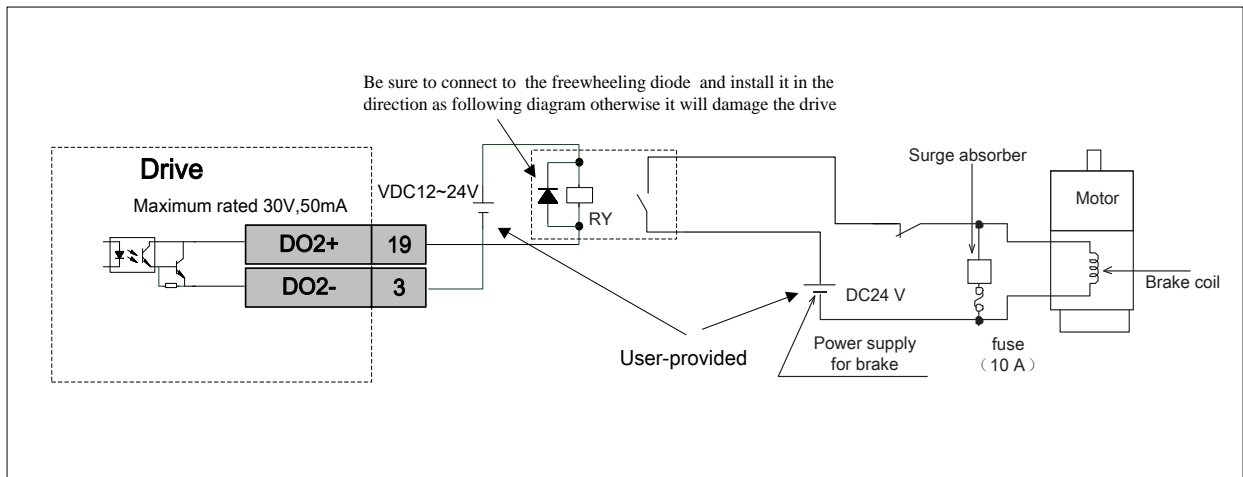

Note: Please prepare a 24V DC power supply.

Precautions for using and wiring the brake:

- ◆ The length of the motor brake cable should fully consider the voltage drop caused by cable resistance. The input voltage for brake operation must be at least 21.6V.
- ◆ It is best not to share the brake power supply with other electrical devices to prevent voltage or current drops caused by the operation of other devices, which could result in brake malfunction.
- ◆ It is recommended to use cables with a cross-sectional area of 0.5mm<sup>2</sup> or higher.
- ◆ For brake enable timing diagrams and related function code settings, please refer to the *FV5 Series Rotary EtherCAT Bus Servo Drive User Manual*.
- ◆ The brake mechanism built into the servo motor is a non-energized action type fixed special mechanism and cannot be used for braking purposes. It is only used to keep the servo motor in a stopped state.
- ◆ After the servo motor is stopped, the servo enable (S-ON) should be disabled.
- ◆ When the motor with a built-in brake is running, the brake may make a clicking sound, which does not affect its functionality.
- ◆ When the brake coil is energized (brake open state), magnetic flux leakage may occur at the shaft end and other parts. Please be cautious when using magnetic sensors and other instruments near the motor.

### 3.4 Wiring of Connector CN2

CN2 is the communication interface between the drive and the PC. Use a USB cable to connect the drive and the PC, enabling parameter setting, monitoring, etc.

Communication cable: Standard USB Type-C cable

Symbol	Connector Pin Number	Description
GND	A1、 B1、 A12、 B12	Signal ground
D+	A6、 B6	Data signal line
D-	A7、 B7	

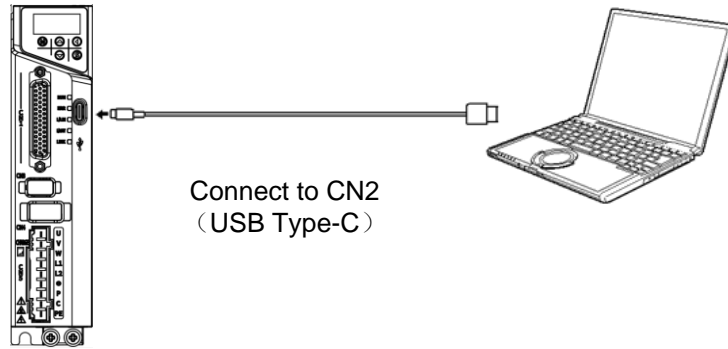

### 3.5 Wiring of Connector CN3

Connector	Connector Number	Pin	Symbol	Description
	1		5V	Encoder +5V power supply
	2		GND	
	3			Serial data transceive signal
	4			
	5		PS+	Connection between the drive interior and PE terminal
	6		PS-	
	Enclosure		PE	

#### 3.5.1 Wiring of the Communication Encoder

- ◆ For single-turn absolute position encoder applications:

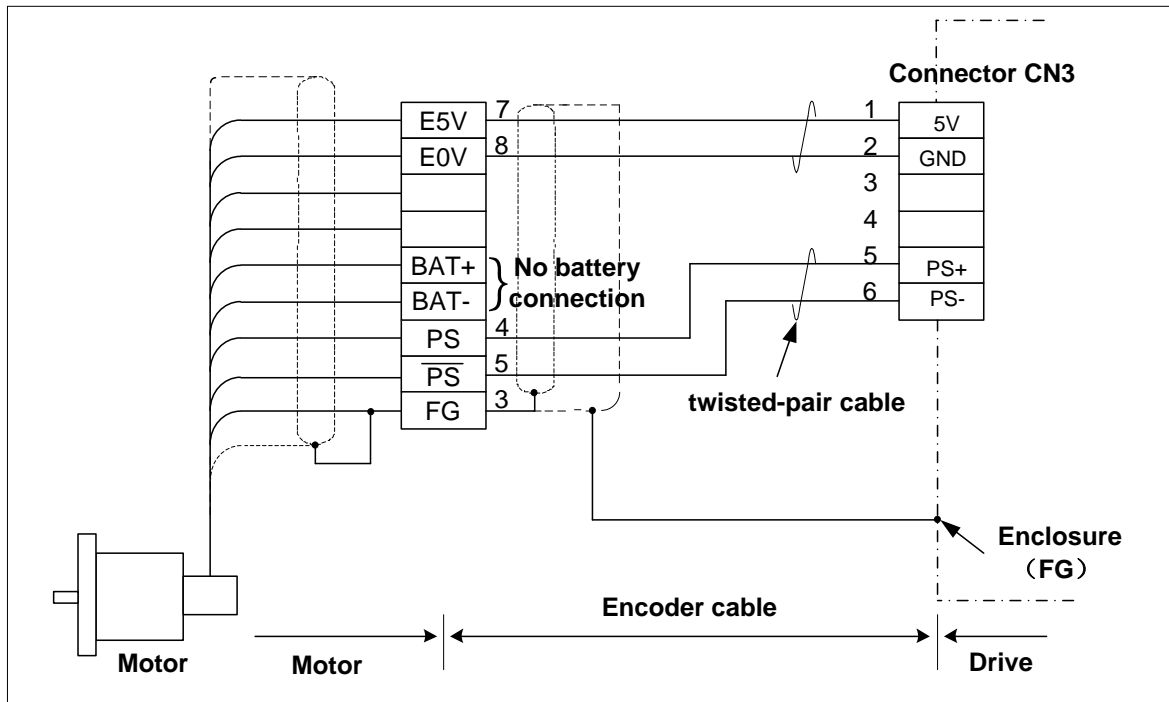

- ◆ For multi-turn absolute position encoder applications:

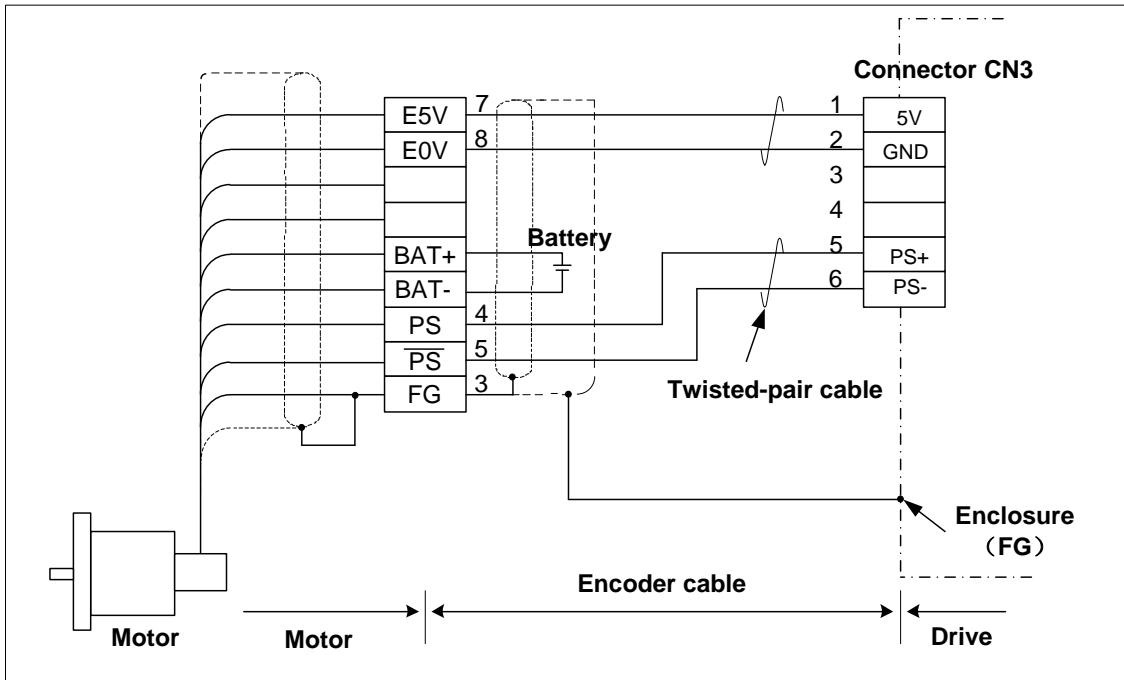

### 3.5.2 Key Points for Wiring of Communication Encoders

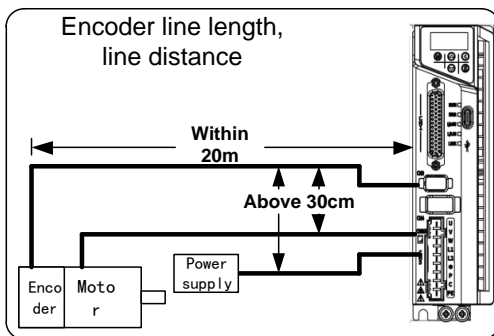

- The cable length between the driver and the motor should be within 20 meters
- Keep a distance of at least 30cm from the main circuit wiring. Do not bundle it together with conduit.

- Tips for making encoder cables

- ① Refer to the wiring illustration
- ② Material: Use wires with a core diameter of at least 0.18mm<sup>2</sup> (AWG 24) and configure them with shielded twisted pair cables that are resistant to bending.

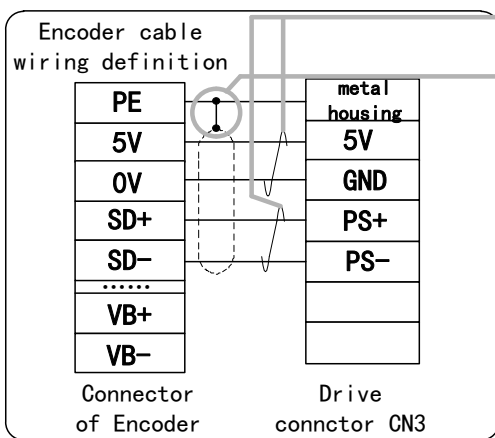

- ③ Use twisted-pair cables for wiring relative signals/power
- ④ Shield layer handling  
Shield layer on the driver side: solder to the enclosure of connector CN3
- ⑤ Do not make any connections to the unused terminals of each connector

### 3.6 Wiring of Connector CN4

### 3.6.1 Wiring of Incremental Encoder

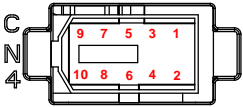
Connector	Connector Number	Pin	Symbol	Description
	1		5V	Encoder power supply
	2		GND	Power and encoder signal ground, connected to the drive internal signal ground
	3		A+	Encoder Phase A signal (twisted pair)
	4		A-	
	5		B+	Encoder Phase B signal (twisted pair)
	6		B-	
	7		Z+	Encoder Phase Z signal (twisted pair)
	8		Z-	
	9		PTC+	Temperature sampling signal (can be left unconnected if no PTC signal)
	10		COM	Temperature sampling signal reference ground (can be left unconnected if no PTC signal)
	Enclosure		PE	The enclosure of the CN4 is connected to the drive PE

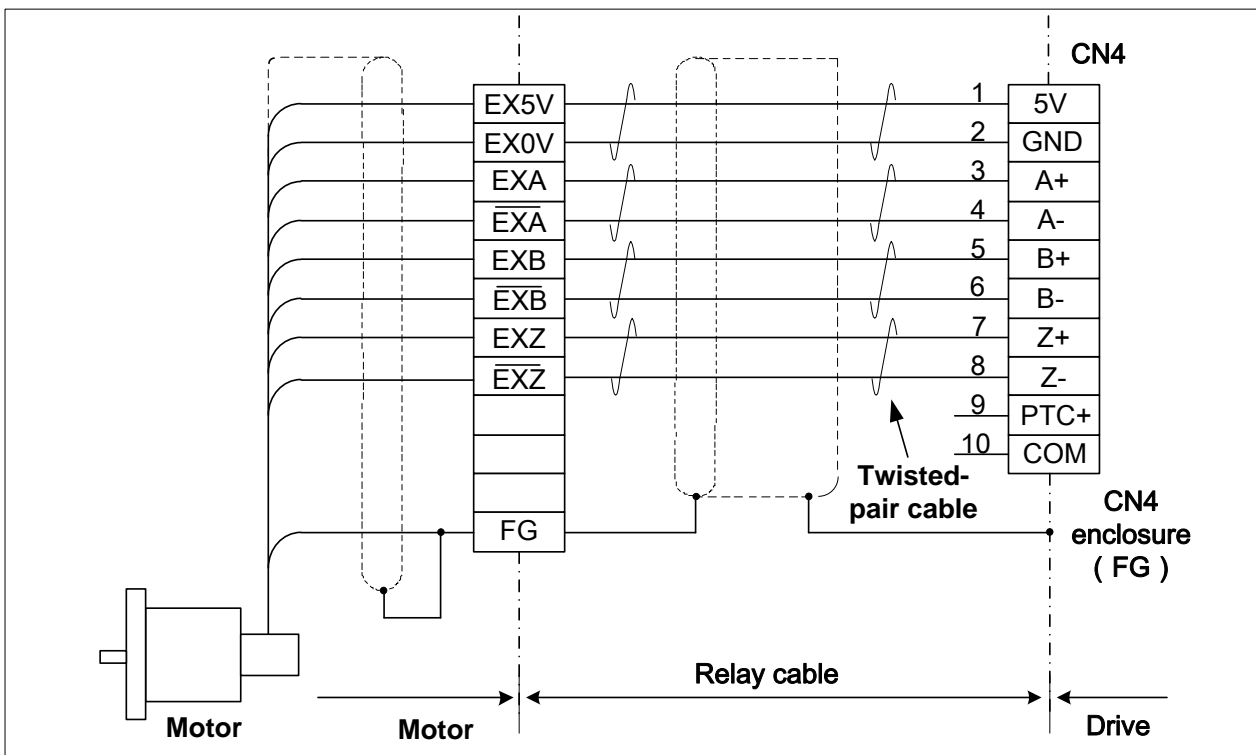

### 3.7 Wiring of Main circuit

### 3.7.1 Main Circuit Terminal Connection Cable Recommendations

SIZE	Servo Drive Model	Rated Input Current (A)	L1C、L2C		L1、L2、L3/R、S、T		P、D、C、⊕		U、V、W、PE		Grounding Terminal	
			mm <sup>2</sup>	AWG	mm <sup>2</sup>	AWG	mm <sup>2</sup>	AWG	mm <sup>2</sup>	AWG	mm <sup>2</sup>	AWG
A	FV5-R*-NA1R1	1.6	-	-	2 × 0.52	20	2 × 0.52	20	4 × 0.52	20	0.52	20
	FV5-R*-NA1R6	2.3	-	-	2 × 0.52	20	2 × 0.52	20	4 × 0.52	20	0.52	20
	FV5-R*-NA2R8	4.0	-	-	2 × 0.52	20	2 × 0.52	20	4 × 0.52	20	0.52	20
B	FV5-R*-NA5R5	7.9	-	-	2 × 0.52	20	2 × 0.52	20	4 × 0.52	20	0.52	20
C	FV5-R*-NC7R6	5.7	2 × 0.52	20	2 × 0.52	20	2 × 0.52	20	4 × 0.81	18	0.52	20
	FV5-R*-NT3R5	2.5	2 × 0.52	20	3 × 0.52	20	2 × 0.52	20	4 × 0.52	20	0.52	20
	FV5-R*-NT5R4	3.8	2 × 0.52	20	3 × 0.52	20	2 × 0.52	20	4 × 0.52	20	0.52	20
D	FV5-R*-NC012	7.3	2 × 1.31	16	3 × 1.31	16	2 × 1.31	16	4 × 1.31	16	0.81	18
	FV5-R*-NT8R4	5.4	2 × 0.52	20	3 × 0.52	20	2 × 0.52	20	4 × 0.81	18	0.52	20
	FV5-R*-NT012	7.9	2 × 1.31	16	3 × 1.31	16	2 × 1.31	16	4 × 1.31	16	0.81	18
E	FV5-R*-NT017	12	2 × 2.08	14	3 × 2.08	14	2 × 2.08	14	4 × 2.08	14	1.31	16
	FV5-R*-NT021	16	2 × 2.08	14	3 × 2.08	14	2 × 2.08	14	4 × 2.08	14	1.31	16
	FV5-R*-NT026	21	2 × 3.33	12	3 × 3.33	12	2 × 3.33	12	4 × 3.33	12	2.08	14

### 3.7.2 Definition of SIZE-A/SIZE-B Connector CN5 Interface

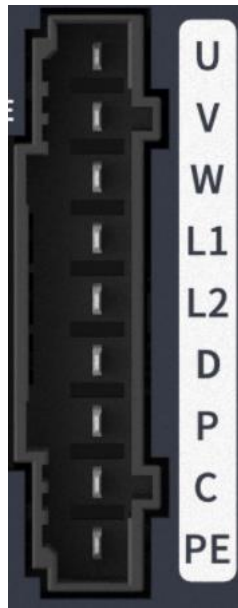

Symbol	Name	Function
U、V、W	Servo Motor Connection Terminals	Connect to the U, V, W phases of the motor
L1、L2	Main Circuit Power Input Terminals	Main circuit single-phase power input, connect AC 220V power supply between L1 and L2
D	Built-in brake resistor connection terminal	Short D and P to use built-in internal discharge resistor.
P、C	Brake Resistor Connection Terminals	External brake resistor connection terminals.
PE	Grounding	Two grounding terminals, connect to the power supply grounding terminal and motor grounding terminal. Please ensure that the entire system is grounded.

### 3.7.3 Definition of SIZE-C/SIZE-D Connector CN5/CN6/CN7 Interface



◆ CN5 Connector Terminals

Symbol	Name	Function
L1C、L2C	Auxiliary Power Input Terminals	Refer to nameplate information to connect to the corresponding voltage level auxiliary power supply.If the input power supply is 220V, access 220V (line voltage); If the input power supply is 380V, access 380V (line voltage).
R、S、T	Main Circuit Power Input Terminals	Refer to nameplate information to connect to the corresponding voltage level main circuit power supply.

◆ CN6 Connector Terminals

Symbol	Name	Function
⊕	DC Bus Negative Voltage Terminal	DC bus terminal of the drive, do not connect when the unit operates standalone.
P、D	Built-in Brake Resistor Connection Terminals	When P and D is short circuit, connect the built-in brake resistor.
C	External Brake Resistor Connection Terminal	When the external brake is connected, connect the resistor to P and C.

◆ CN7 Connector Terminals

Symbol	Name	Function
U、V、W	Servo Motor Connection Terminals	Connect to the phase U, V, W of the motor

Refer to System Wiring and Key Points Description for main circuit wiring and precaution.

### 3.7.4 Definition of SIZE-E Connector CN5 Interface

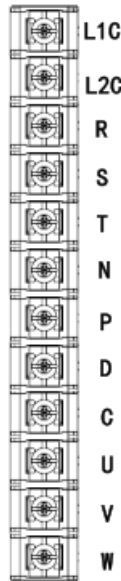

The terminal definitions of the SIZE-E CN5 connector are the same as the terminal definitions of SIZE-C/SIZE-D CN5/CN6/CN7 connector. Please refer to Definition of SIZE-C/SIZE-D Connector CN5/CN6/CN7 Interface .

### 3.7.5 Brake Resistor Selection and Wiring Precautions

- ◆ Do not directly connect the external brake resistor to the terminals P and  $\ominus$  (D), as this will cause an explosion and fire.
- ◆ Before using the drive, please confirm that the brake resistor parameters P02.20, P02.23, P02.24 have been correctly set.
- ◆ Please install the external braking resistor on metal or other non-combustible materials.

### 3.8 Wiring of EtherCAT Communication Port

Symbol	Connector Number	Pin	Function
TX+	1		Data transmit positive
TX-	2		Data transmit negative
RX+	3		Data receive positive
RX-	6		Data receive negative
PE	Enclosure		Shielding

Use Cat5e or Cat6 cables to connect the host and servo drives (the IN port of the first servo drive is connected to the Ethernet port of the host, the OUT port is connected to the IN port of the second servo drive, the OUT port of the second servo drive is connected to the IN port of of the third servo drive, and so on). Set each servo drive's P08.12 to modify the EtherCAT slave alias, the setting value range from 0 to 65535 (16#0~FFFF).

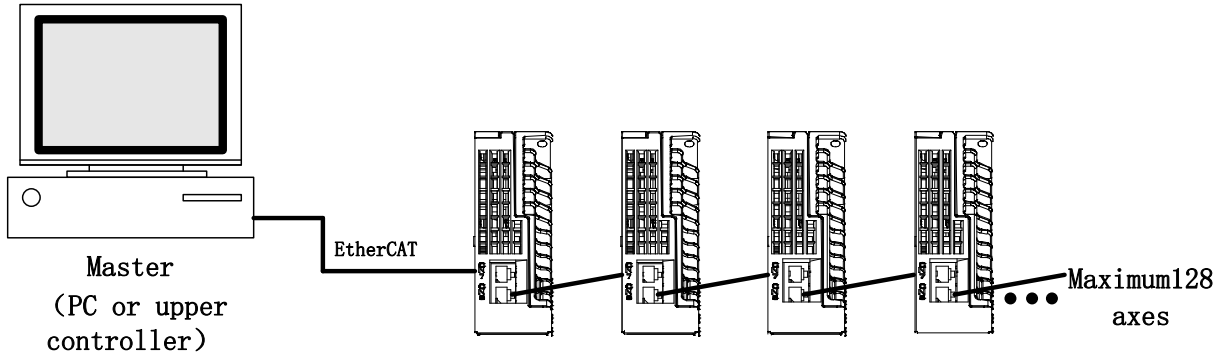

### 3.9 Wiring of Connector CN9 (Applicable to the U3 Series)

CN9	Pin number	Symbol	Function
	1	COM	STO reference ground
	2	STO1+	STO1 input
	3	24V	24V power supply
	4	STO2+	STO2 input

- ◆ When STO1 and STO2 input is high (input 24V), the drive can function properly, any STO input is low, the drive alarm A1.06.1, not working properly.
- ◆ When the STO function is not required, STO1 and STO2 terminals must be short to 24V terminals.

Use internal 24V or external 24V power when using STO functionality.

#### 3.9.1 Wiring method When Using External 24V Power Supply

Safety input signal specifications are as follows.

- ◆ Input voltage range: 24V DC, -15%~+15%
- ◆ Input current: About 5mA (typ) each channel
- ◆ Logic level: low-level<3V; high-level>16V

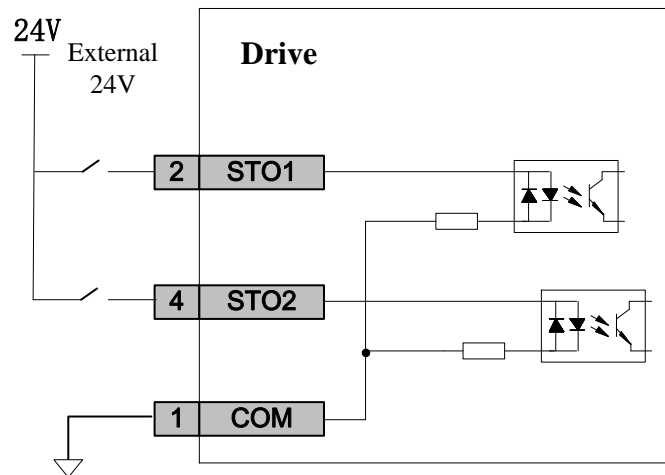

### 3.9.2 Wiring method When using Internal 24V Power Supply

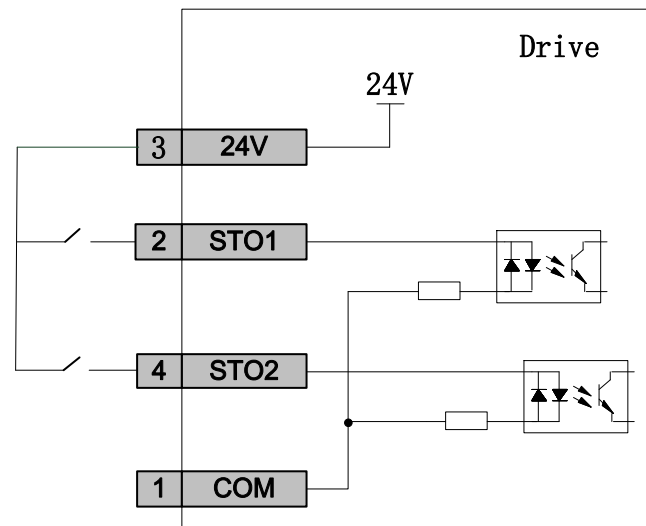

- ◆ Two STO inputs use separate wires, the cable type must be shielding cable, double shielding or single shielding twisted pair cable is recommended.
- ◆ Maximum length between drive and safety switches is 30m.

### 3.10 Motor Side Connector Wiring

Definition of motor encoder cable connector			
Motor model	Pins of motor encoder connector	Definition of pins	
		SN	Definition
EAM-W series motor lead connector type		1	E+
		2	E-

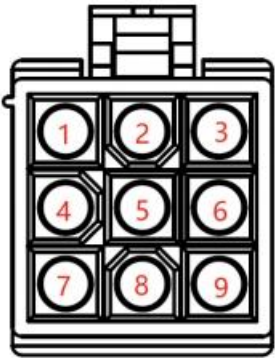
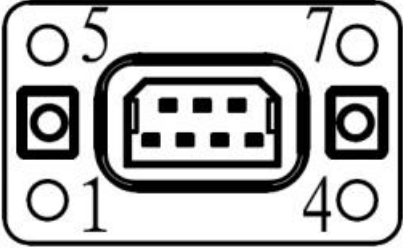
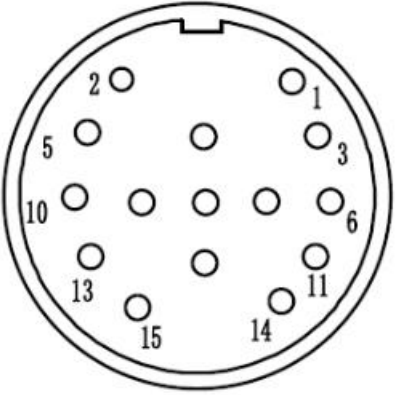
<p>motor(flange size: 40)                      leaded connector type</p> <p>motor(flange size: 60)                      leaded connector type</p> <p>motor(flange size: 80)</p>		<p>3</p> <p>4</p> <p>5</p> <p>6</p> <p>7</p> <p>8</p> <p>9</p>	<p>PE</p> <p>PS+</p> <p>PS-</p> <p>-</p> <p>5V</p> <p>0V</p> <p>-</p>
<p>EAM-W series motor                      Terminal connector type</p> <p>motor(flange size: 40)                      Terminal connector type</p> <p>motor (flange size: 60)                      Terminal connector type</p> <p>motor (flange size:80)</p>		<p>SN</p> <p>1</p> <p>2</p> <p>3</p> <p>4</p> <p>5</p> <p>6</p> <p>7</p>	<p>Definition</p> <p>PS+</p> <p>PS-</p> <p>E+</p> <p>E-</p> <p>5V</p> <p>0V</p> <p>PE</p>
<p>W series standard motor                      aviation plug type</p> <p>motor(flange size: 100)                      aviation plug type</p> <p>motor(flange size: 110)                      aviation plug type</p> <p>motor(flange size: 130)                      aviation plug type</p> <p>motor(flange size: 180)                      aviation plug type</p>		<p>SN</p> <p>1</p> <p>2</p> <p>3</p> <p>4</p> <p>5</p> <p>6</p> <p>7</p> <p>8</p> <p>9</p>	<p>Definition</p> <p>PE</p> <p>5V</p> <p>0V</p> <p>-</p> <p>-</p> <p>-</p> <p>-</p> <p>-</p> <p>-</p>

	10	PS+
	11	-
	12	E+
	13	PS-
	14	-
	15	E-

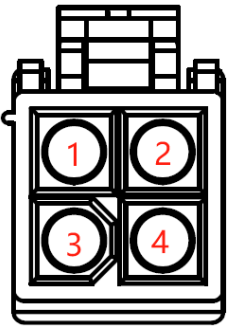
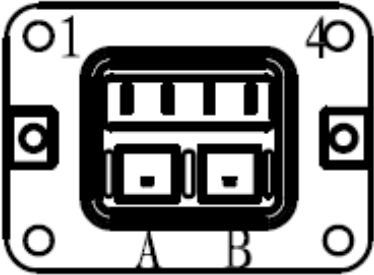
Definition of motor power cable connector			
Motor model	Pins of motor connector	Definition of pins	
		SN	Definition
EAM-W series motor Leaded connector type motor (flange size: 40) Leaded connector type motor (flange size: 60) Leaded connector type motor (flange size: 80)		1	U
		2	V
		3	W
		4	PE
EAM-W series motor Terminal connector type motor (flange size:40) Terminal connector type motor (flange size:60) Terminal connector type motor (flange size:40) Terminal connector type motor (flange size:80)		SN	Definition
		1	V
		2	U
		3	W
		4	PE
		A	24V
		B	0V
EAM-W series motor Aviation plug type motor(flange size: 100) Aviation plug type		SN	Definition
		1	PE
		2	U

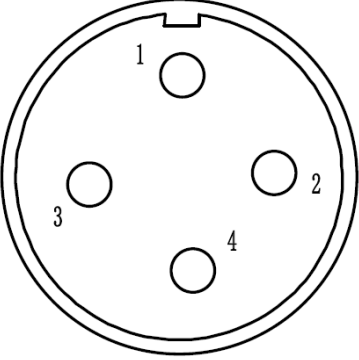
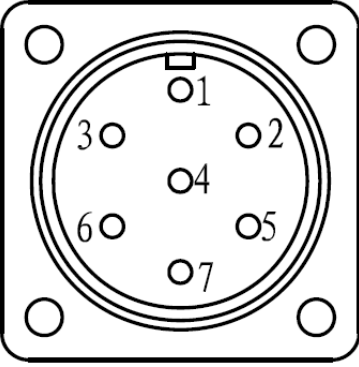
<p>motor(flange size: 110) Aviation plug type motor(flange size: 130) Aviation plug type motor(flange size: 180)</p>		3	V
<p>EAM-W series motor with brake Aviation plug type motor(flange size: 100) Aviation plug type motor(flange size: 110) Aviation plug type motor(flange size: 130) Aviation plug type motor(flange size: 180)</p>		SN	Definition
		1	PE
		2	U
		3	V
		4	W
		5	24V
		6	0V
		7	-

Definition of motor brake cable connector			
Motor model	Pins of motor connector	Definition of pins	
		SN	Definition
<p>EAM-W series motor Leaded connector type motor (flange size: 40, 60, and 80)</p>		1	24V
		2	0V
<p>EAM-W series motor Aviation plug type motor (flange size: 100, 110, and 130)</p>		SN	Definition
		1	24V
		2	0V

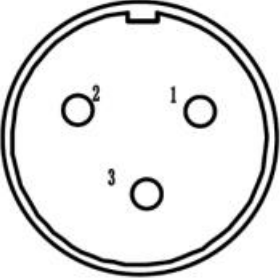
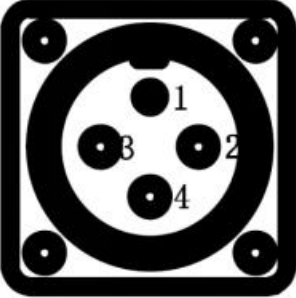
		3	-										
<p>EAM-W series motor with brake</p> <p>Aviation plug type motor (flange size: 180)</p>		<table border="1"> <thead> <tr> <th data-bbox="1061 519 1200 584">SN</th> <th data-bbox="1200 519 1353 584">Definition</th> </tr> </thead> <tbody> <tr> <td data-bbox="1061 584 1200 667">1</td> <td data-bbox="1200 584 1353 667">24V</td> </tr> <tr> <td data-bbox="1061 667 1200 750">2</td> <td data-bbox="1200 667 1353 750">0V</td> </tr> <tr> <td data-bbox="1061 750 1200 833">3</td> <td data-bbox="1200 750 1353 833">/</td> </tr> <tr> <td data-bbox="1061 833 1200 916">4</td> <td data-bbox="1200 833 1353 916">/</td> </tr> </tbody> </table>	SN	Definition	1	24V	2	0V	3	/	4	/	
SN	Definition												
1	24V												
2	0V												
3	/												
4	/												

### 3.11 Electromagnetic Interference Suppression

#### 3.11.1 Anti- electromagnetic interference Wiring Example

The main circuit of this servo drive uses "high-speed switch elements". Depending on the periphery wiring and local processing of the servo drive, switch noise may affect the normal operation of the system. Therefore, correct grounding methods and local processing must be adopted, and noise filters should be added when necessary.

In order to ensure a good electromagnetic compatibility environment, it is important to use the illustrated single-point grounding method for grounding.

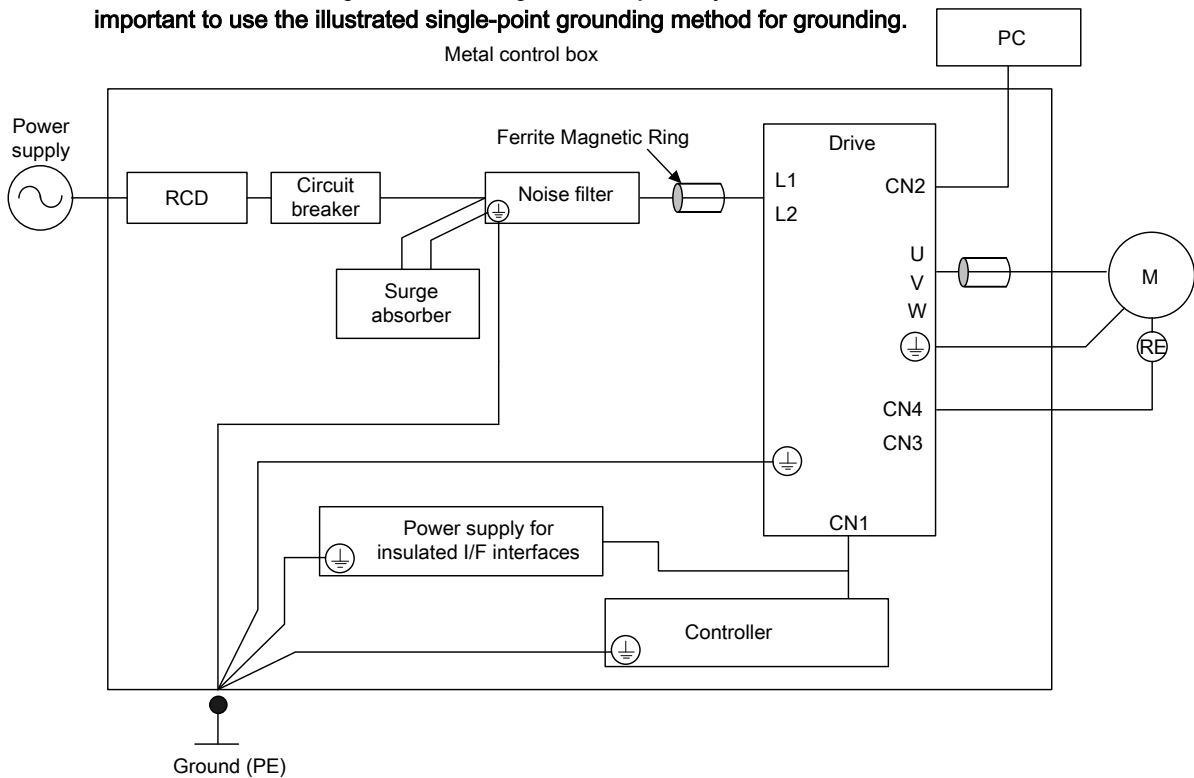

### 3.11.2 Grounding

To avoid potential electromagnetic interference, please ground as follows:

- ◆ The servo drive must be reliably grounded to the main power supply's grounding line, and the grounding screw must be tightened.
- ◆ The controller connected to the servo drive must have its grounding line ultimately connected to the same grounding point as the servo drive's grounding line.
- ◆ Connect the ground of the servo motor to the grounding screw of the servo drive and ensure reliable grounding to reduce potential electromagnetic interference.
- ◆ The shielding layer metal conduit in the motor main circuit should be grounded at both ends. It is recommended to use crimping method to ensure good connection.

### 3.11.3 How to Use Input Power Filter and Noise Filter

To prevent interference from the power cable, add an EMC filter to the input power cable of the servo drive. Choose an appropriate EMC filter at the power input end based on the input current. When installing and wiring the EMC filter, please observe the following precautions.

- ◆ Separate the input and output wiring of the EMC filter and avoid bundling them or placing them in the same cable slot.
- ◆ Separate the ground wire of the EMC filter from its output power cable.
- ◆ It is recommended to mount the EMC filter on the same metal plate as the servo drive and ensure good electrical contact with the metal plate. Ground the metal plate separately with thick wires as much as possible, and place the filter near the drive as close as possible to prevent coupling noise.
- ◆ If multiple Servo Drives are used and a noise filter is to be shared in the power supply section, consult with the noise filter manufacturer.

- ◆ When using the same wiring duct for routing, the noise resistance function is reduced. As shown in the figure below:

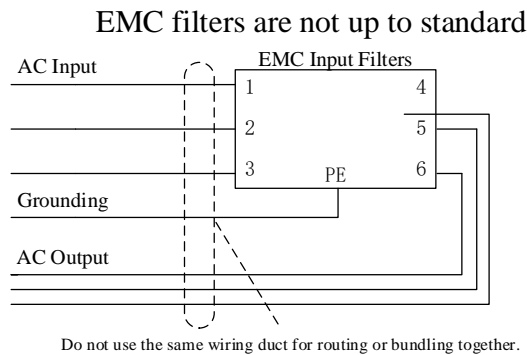

The AC input reactor and EMC filter installation schematic is shown below:

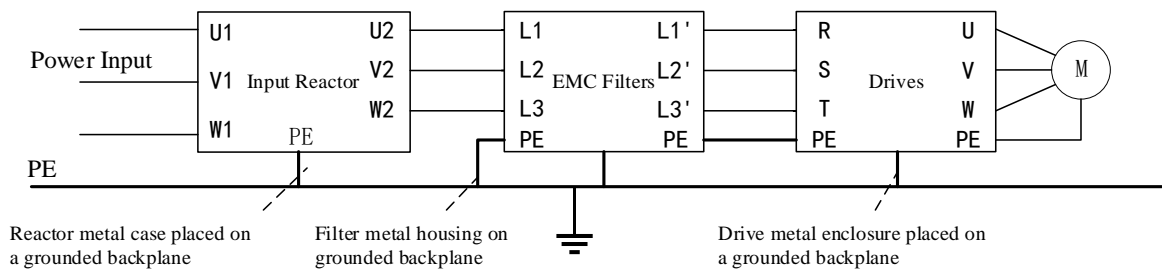

### 3.11.4 Magnetic Rings

To ensure that the magnetic ring is effective in suppressing electromagnetic interference (EMI) at the input and output of the drive, follow the installation guidelines below to fully utilize the magnetic ring:

- ◆ The magnetic ring should be mounted on the input or output side of the drive and as close to the drive as possible, up to a maximum of 30cm.
- ◆ The number of turns should not be too few or too many when winding the magnetic ring, usually 3 to 5 turns are recommended.
- ◆ Ensure that the cable is wrapped evenly and tightly around the magnetic ring, avoiding loose or cross-winding.
- ◆ When winding the magnetic ring for the RST cable or UVW cable, make sure that all three wires for RST or all three wires for UVW pass through the ring at the same time. Note that the PE wire (ground wire) should not be wound into the magnetic ring.
- ◆ Magnetic rings are fragile. Avoid violent impacts on the rings during use.

The following figure shows an example of winding of a magnetic ring:

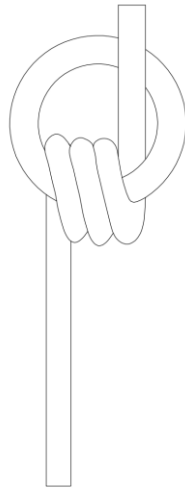

### 3.11.5 Other Suggestions on Electromagnetic Interference Suppression

To suppress electromagnetic interference, please take the following measures:

- ◆ Arrange power supply and control cables separately. It is recommended to keep a distance of at least 30 cm to improve anti-interference.
- ◆ If the input power cable and signal cable need to cross, ensure they cross at a 90° angle.
- ◆ Keep the wiring as short as possible, as excessive length may cause shielding interruptions and signal interference.
- ◆ Use thick wires (above 2.0 mm<sup>2</sup>) for grounding as much as possible.
- ◆ Ensure to ground at a single point.
- ◆ Do not share the power supply with welding machines, discharge processing equipment, etc.

## 4 Appendix

### 4.1 Compliance with Certifications and Standards

Certification	Directive Name		Standard
CE certification	EMC directive	2014/30/EU	EN IEC 61800-3
	LVD directive	2014/35/EU	EN 61800-5-1

The drive complies with the latest version of directives and standards for CE certifications.

#### 4.1.1 CE Certification

- ◆ The CE mark indicates compliance with the Low Voltage Directive (LVD), Electromagnetic Compatibility (EMC), and Restriction of Hazardous Substances (RoHS) directives.
- ◆ The CE mark is required for engaging in commercial business (production, importation, and distribution) in Europe.
- ◆ The drive complies with LVD, EMC, and RoHS directives and carries the CE mark.
- ◆ Machines and devices integrated with this drive must also comply with CE requirements for distribution in Europe.
- ◆ The integrator who integrates this drive into other products and attaches CE mark to the final assembly has the responsibility of ensuring compliance with CE certification

##### 4.1.1.1 Requirement for Compliance with EMC Directive

The SV660P series servo drive, which is applicable to second environment, complies with EMC Directive 2014/30/EU and standard EN IEC 61800-3. As required by EMC Directive 2014/30/EU and standard EN IEC 61800-3, install an EMC filter on the input side of the drive and use shielded cables on the output side. Ensure the filter is grounded properly and the shield of the output cable is grounded 360 degrees

#### Introduction to EMC standards

Electromagnetic compatibility (EMC) describes the ability of electrical and electronic devices to work properly in the electromagnetic environment without introducing electromagnetic interferences that disturb the operation of other local devices or systems. In other words, EMC includes two aspects: 1) The electromagnetic interference generated by a device during normal operation cannot exceed a certain limit. 2) The device must have sufficient immunity to the electromagnetic interference in the environment.

ENIEC 61800-3 defines the following two types of environments.

- ◆ Category I environment: Environment that includes domestic premises, and establishments directly connected without intermediate transformers to a low voltage power supply network which supplies buildings used for domestic purposes.
- ◆ Category II environment: Environment that includes all establishments other than those directly connected to a low-voltage power supply network which supplies buildings used for domestic purposes.

Drives are divided into the following four categories based on the intended application environment.

- ◆ Category C1 drive: Power drive system (PDS) with rated voltage less than 1000 V, intended for use in the Category I environment

- ◆ Category C2 drive: PDS with rated voltage less than 1000 V, which is neither a plug in device nor a movable device and, when used in the Category I environment, is intended to be installed and commissioned only by professionals.
- ◆ Category C3 drive: PDS with rated voltage less than 1000 V, intended for use in the Category II environment and not intended for use in the Category I environment.
- ◆ Category C4 drive: PDS with rated voltage equal to or above 1000 V, or rated current equal to or above 400 A, or intended for use in complex systems in the Category II environment.

#### 4.1.1.2 Requirements for Compliance with LVD

The drive has been tested in accordance with EN61800-5-1 to determine compliance with LVD. Observe the following requirements to enable machines and devices integrated with this drive to comply with LVD.

- ◆ Installation location  
Install the drive in a place with overvoltage category III and pollution degree 1 or 2 as specified by IEC 60664-1.
- ◆ Installation environment  
For requirements of the installation environment, see [Installation Environment Conditions](#).
- ◆ Protective requirements of installation  
The drive must be installed in a fireproof cabinet with doors that provide effective electrical and mechanical protection. The installation must conform to local and regional laws and regulations and relevant IEC standards. Drives (IP20) intended to be installed inside the cabinet must be installed in a structure that prevents intrusion of unwanted objects from the top and the front.
- ◆ Main circuit wiring requirements  
For wiring requirements of main circuit terminals, see [Wiring of Main circuit](#).
- ◆ Requirements of protective devices  
To comply with EN61800-5-1, install a fuse/circuit breaker on the input side of the drive to prevent accidents caused by short circuit in the internal circuit.